



INSTALLATION, OPERATION & MAINTENANCE MANUAL IOM1003

PNEUMATIC DOUBLE ACTING (DA) LINEAR ACTUATOR

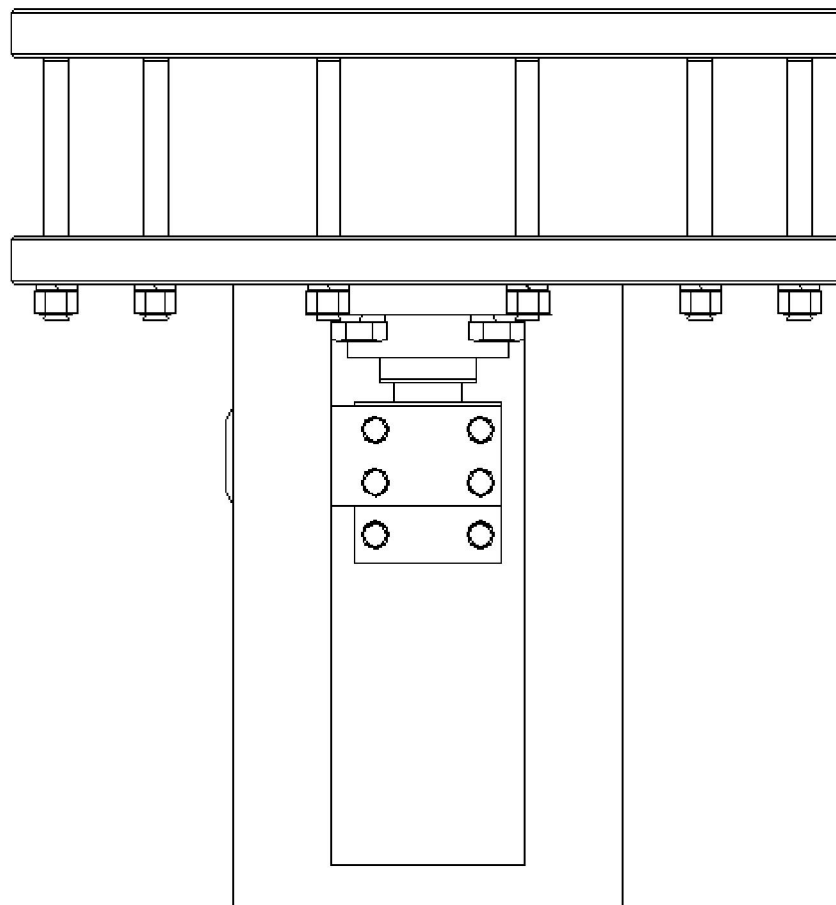



Table of Contents

1	Introduction	1
1.1	Company Background	1
1.2	Scope & Purpose of Manual	1
1.3	Company Contact	1
2	Reference Documents	1
3	Definitions	2
4	Product Description	3
4.1	General Description & Typical Applications	3
4.2	Product Operation	3
4.3	Product Specifications	4
5	Safety Warnings	7
5.1	Personnel Requirements	7
5.2	Potential Hazards	8
6	Handling and Storage	9
6.1	Receiving the Product	9
6.2	Storage and Preservation	10
7	Installation Instructions	10
7.1	Mount to Valve Body	10
7.2	Connection to Valve Stem	11
7.3	Setting the Stroke Length	12
7.4	Setting the Stroke Time	12
8	Preparation for Start-up	13
8.1	Pneumatic Connections	13
8.2	Electrical Connections	13
8.3	Start-up	13
9	Maintenance	14
9.1	Safety Reminder	14
9.2	Lubricating Mechanism	16
9.3	Parts Ordering	16
10	Disposal	17
11	Terms and Conditions/Warranty	18
12	Revision Record	20

Appendices



1 Introduction

1.1 Company Background

Automation Technology was founded in 1995 as a manufacturer of pneumatic and hydraulic valve actuators. With products in a wide range of applications such as petrochemical, pipelines, refineries, pulp and paper, agriculture, pharmaceutical, municipalities, mining, power plants and marine transportation, ATI has succeeded in becoming a global leader in automation technology.

1.2 Scope & Purpose of Manual

This manual is intended to assist those who are involved with the installation, operation and maintenance of the ATI Pneumatic Double Acting (DA) Linear Actuator. This manual should be reviewed and thoroughly understood PRIOR to installing, operating or providing maintenance on the device. Refer to separate instruction manuals for details regarding optional accessories and other equipment used with these actuators.

Failure to read and comply with all applicable installation, operation and maintenance instructions may result in bodily injury or equipment damage and will void the Product warranty.

1.3 Company Contact

For any questions or clarifications, contact ATI or your nearest ATI Authorized Representative.

Email: Sales@ATIactuators.com

Web: <http://www.ATIactuators.com/>

ATI Global Headquarters – Customer Support, Design & Manufacturing
Houston, Texas, USA
Phone: +1 713 934-0171
US Toll Free: 800-924-8037

ATI Europe – Customer Support
Manchester, United Kingdom
Phone: +44 161 830-2146

2 Reference Documents

The following documents are referenced within this publication. These address options and accessories, and one or more of these documents are required to complete installation, operation or maintenance of the as-built Product.

- IOMS 001 ATI Linear Pneumatic Actuator Thrust Chart
- IOMS 002 ATI JS2 Bi-directional Mechanical Override
- IOMS 003 ATI HO1/HO2 Hydraulic Override
- IOMS 004 ATI Fastener Torque Guide
- IOMS 005 ATI HD Threaded Coupling Valve Stem Connection
- IOMS 006 ATI Split Coupling Valve Stem Connection
- IOMS 007 ATI Troubleshooting Guide
- IOMS 008 ATI Hydraulic Snubber
- IOMS 009 ATI Bearing Seal Field Repair



3 Definitions

Term/Abbreviation	Definition
bore size	Nominal Inside Diameter of the power cylinder of the Product. Standard Bore Sizes are listed in IOMS001.
cycle	Operating the actuator from full open to full close and back to full open, or from close to open, back to close. When mounted to the valve, this is 2 full stroke operations, one time in each direction.
MAST	Maximum Allowable Stem Thrust. The maximum thrust, as specified by the valve manufacturer, that can be safely applied the valve stem.
MAWP	Maximum Allowable Working Pressure, or Maximum Allowable Operating Pressure (MAOP). The maximum design pressure for the Product.
pneumatic actuator	A pneumatic actuator uses compressed air or inert gas as the fluid power medium to produce mechanical motion.
Product	Pneumatic Double Acting (DA) Linear Actuator. "Product" in this manual refers to the Applicable Product for this publication as defined in section 1.2.
stroke	Measure of valve openness. Full stroke is the travel distance to move the valve from its full closed to its full open position. In control valve applications, stroke is often described in percentage terms—full closed is 0%, full open is 100%—and stroke is generally proportional to the amount of flow through the pipe.
travel	Measure of the distance of linear actuator movement. The maximum travel is determined by the internal design gaps between the actuator piston and internal surfaces of actuator heads or other fixed stops. Maximum travel usually exceeds Stroke requirements, and adjustable travel stops are used to limit travel to match the stroke requirement and to prevent over-travel that can damage the valve or other equipment.



4 Product Description

4.1 General Description & Typical Applications

ATI linear actuators are suitable for operating valves, dampers, and other industrial equipment, in On-Off and Modulating heavy-duty service. The ATI Pneumatic Double Acting (DA) Linear Actuator is a double-acting piston actuator that provides high thrust output with minimal friction for short- and long-stroke applications, including rising-stem valves and other industrial, fluid-handling process equipment.

The actuator includes a flange that will mount directly to the valve or to an adapter flange that mounts to the valve bonnet or to a mounting flange of the damper or other equipment. ATI supplies a flange that is custom machined to fit the application.

The actuator includes a coupling or clevis for the connection of the actuator piston rod to the valve stem or other equipment. Refer to IOMS005 and IOMS006 for common coupling options.

Adjustable stops are available as an option to limit actuator travel and protect the valve stem or other equipment from potential actuator thrust limits at full supply pressure.

The actuator is available with an optional mechanical override or with an optional hydraulic override or hydraulic snubber. The overrides allow for valve operation in the case of a loss of pneumatic supply pressure. The snubber is available for speed control, to dampen sudden movements to the actuator due to process conditions. Refer to IOMS002, IOMS003 and IOMS008 for more information.

The actuator is designed for assembly of optional accessories (positioner, signaling limit switches, position transducer, etc.) by means of mechanical linkages. These accessories are generally attached to the linear actuator's stem coupling.

ATI can supply different types of control systems following customer requirements.

4.2 Product Operation

The Product utilizes a pneumatically-controlled piston that is sealed against the inside of a cylinder. Supply pressure acts against the piston to generate thrust that varies with the differential pressure across the fixed area of the piston.

From equilibrium, the actuator operates by differential of forces that is created by increasing supply pressure on one side of the piston (and/or decreasing pressure on the opposite side of the piston). This pressure differential causes the piston to move up or down, changing the position of the actuator and the valve or other device to which it is connected.

Travel of the actuator is limited by the total travel of the piston within the cylinder, and travel can be adjusted to a shorter distance using external, optional travel stops that are typically found in the coupling to the valve stem. Refer to IOMS005 and IOMS006 for common options for external, adjustable stops.

Optional manual overrides are available to extend or retract the actuator on loss of supply pressure or loss of control signal. Refer to IOMS002 and IOMS003 for more information.

4.2.1 Pneumatic Operation – Retract

When supply pressure is applied to the port(s) of the lower head and pressure is exhausted from the port(s) of the upper head, the piston drives the actuator to retract the piston rod. In a typical push-to-close valve design, supply pressure to the lower head retracts the piston rod to *open* the valve.



4.2.2 Pneumatic Operation – Extend

When supply pressure is applied to the port(s) of the upper head and pressure is exhausted from the port(s) of the lower head, the piston drives the actuator to extend the piston rod. In a typical push-to-close valve design, supply pressure to the upper head extends the piston rod to *close* the valve.

4.2.3 Manual Operation

Refer to IOMS002 & IOMS0003, as applicable, for details on operation of JS2 mechanical override or the HO2 hydraulic override.

4.3 Product Specifications

<p>4.3.1 Operating Pressure</p>	<p>The working pressure range for a standard ATI Pneumatic Double Acting (DA) Linear Actuator is as follows:</p> <p>MINIMUM: 30 psig (2 bar) MAXIMUM (MAWP): 150 psig (10.3 bar)</p> <p>Consult ATI for supply pressure outside of these Min. & Max. limits.</p>																															
<p>4.3.2 Temperature Limits</p>	<p>Operating Temperature of the Product varies with seal selection at the time or order placement:</p> <table border="1" data-bbox="646 808 1388 1003"> <thead> <tr> <th>Seal Material</th> <th>Operating Temperature</th> </tr> </thead> <tbody> <tr> <td>Nitrile (Buna, NBR) – standard</td> <td>-40°F to +200°F (-40°C to +93°C)</td> </tr> <tr> <td>Low-temp Nitrile (Buna, NBR)</td> <td>-65°F to +200°F (-54°C to +93°C)</td> </tr> <tr> <td>FKM (Viton)</td> <td>-20°F to +400°F (-29°C to +204°C)</td> </tr> </tbody> </table> <p>Ambient Temperature recommendation</p> <table border="1" data-bbox="799 1054 1409 1285"> <thead> <tr> <th rowspan="2">MINIMUM: Bore Size</th> <th colspan="3">Min. Ambient Temperature @ Max. Pressure</th> </tr> <tr> <th>65 psi (4.5 bar)</th> <th>95 psi (6.5 bar)</th> <th>150 psi (10.3 bar)</th> </tr> </thead> <tbody> <tr> <td>4-12</td> <td>-65°F (-54°C)</td> <td>-65°F (-54°C)</td> <td>-65°F (-54°C)</td> </tr> <tr> <td>14-22</td> <td>-65°F (-54°C)</td> <td>-65°F (-54°C)</td> <td>-52°F (-46°C)</td> </tr> <tr> <td>24-36</td> <td>-65°F (-54°C)</td> <td>-58°F (-50°C)</td> <td>-40°F (-40°C)</td> </tr> <tr> <td>38-44</td> <td>-58°F (-50°C)</td> <td>-40°F (-40°C)</td> <td>-23°F (-30°C)</td> </tr> </tbody> </table> <p><i>Recommended MINIMUM Ambient Temperature is based on impact testing exemptions per ASME VIII UCS-66 for ATI standard materials.</i> <i>* For actuators specified to meet optional PED certification (reference 4.3.13), the MINIMUM Ambient Temperature rating for ATI standard materials is limited to -4 °F (-20 °C). If lower temperatures are specified with order, ATI can manufacture Product using materials with certified impact test results at the specified minimum temperature.</i></p> <p>MAXIMUM: +122°F (+50°C) <i>Recommended MAXIMUM Ambient Temperature is based on the burn threshold established in ISO 13732-1; maintaining a surface temperature at or below this value ensures safety of personnel that may contact the equipment. Standard materials of construction are otherwise suitable to the maximum Operating Temperature of all seals, +400°F (+204°C).</i></p> <p>Consult ATI for alternate seal constructions for special applications.</p>	Seal Material	Operating Temperature	Nitrile (Buna, NBR) – standard	-40°F to +200°F (-40°C to +93°C)	Low-temp Nitrile (Buna, NBR)	-65°F to +200°F (-54°C to +93°C)	FKM (Viton)	-20°F to +400°F (-29°C to +204°C)	MINIMUM: Bore Size	Min. Ambient Temperature @ Max. Pressure			65 psi (4.5 bar)	95 psi (6.5 bar)	150 psi (10.3 bar)	4-12	-65°F (-54°C)	-65°F (-54°C)	-65°F (-54°C)	14-22	-65°F (-54°C)	-65°F (-54°C)	-52°F (-46°C)	24-36	-65°F (-54°C)	-58°F (-50°C)	-40°F (-40°C)	38-44	-58°F (-50°C)	-40°F (-40°C)	-23°F (-30°C)
Seal Material	Operating Temperature																															
Nitrile (Buna, NBR) – standard	-40°F to +200°F (-40°C to +93°C)																															
Low-temp Nitrile (Buna, NBR)	-65°F to +200°F (-54°C to +93°C)																															
FKM (Viton)	-20°F to +400°F (-29°C to +204°C)																															
MINIMUM: Bore Size	Min. Ambient Temperature @ Max. Pressure																															
	65 psi (4.5 bar)	95 psi (6.5 bar)	150 psi (10.3 bar)																													
4-12	-65°F (-54°C)	-65°F (-54°C)	-65°F (-54°C)																													
14-22	-65°F (-54°C)	-65°F (-54°C)	-52°F (-46°C)																													
24-36	-65°F (-54°C)	-58°F (-50°C)	-40°F (-40°C)																													
38-44	-58°F (-50°C)	-40°F (-40°C)	-23°F (-30°C)																													
<p>4.3.3 Fluid Type</p>	<p>The Product is designed for standard pneumatic service, with clean, dehydrated compressed air or inert gas other than helium.</p> <p>The Product may also be operated with filtered, lubricated air. Refer to section 9.2 for more information.</p>																															







4.3.4 Duty Cycle & Cycle Speed	<p>The Product is capable of intermittent duty and continuous modulation when operated within recommended temperature limits with properly filtered fluid.</p> <p>Consult ATI for cycle speeds faster than 0.5 second per inch of travel. Speeds faster than 1 second for full stroke have been achieved with proper sizing and system design.</p>																					
4.3.5 Service Life	<p>ATI actuators can be operated up to 5 years without maintenance. In harsh environments and safety critical applications, more frequent maintenance intervals should be considered to ensure reliable Product performance.</p> <p>With regularly schedule maintenance using genuine ATI components (seals), the service life of an ATI Pneumatic Double Acting (DA) Linear Actuator has been extended to 20 years and longer.</p>																					
4.3.6 Lubrication	<p>For normal duty, the actuator is lubricated for the life of the Product. In case of high load and high frequency of operation it may be necessary to periodically restore the lubrication. Refer to section 9.2 for additional information on maintaining lubrication grease.</p>																					
4.3.7 Lifting Point Load Ratings	<p>Actuators are provided with a provision for lifting the actuator.</p> <table border="1" data-bbox="646 772 1239 1024"> <thead> <tr> <th>Bore Size</th> <th>Typical Lifting Provision</th> <th>Load Rating lbf (kN)</th> </tr> </thead> <tbody> <tr> <td>4-8</td> <td>2X 3/8-16UNC</td> <td>2300 (10.6)</td> </tr> <tr> <td>10</td> <td>2X 1/2-13UNC</td> <td>4300 (19.3)</td> </tr> <tr> <td>12-20</td> <td>2X 5/8-11UNC</td> <td>6900 (30.7)</td> </tr> <tr> <td>22-24</td> <td>2X 3/4-10UNC</td> <td>10000 (44.8)</td> </tr> <tr> <td>26-28, 38</td> <td>2X 7/8-9UNC</td> <td>13800 (61.7)</td> </tr> <tr> <td>30-36, 40-44</td> <td>2X 1-8UNC</td> <td>18300 (81.4)</td> </tr> </tbody> </table> <p>Review sections 5.2 and 6.1 for safety warnings before lifting the Product. Follow the installation, operation and safety instructions for the hoist rings, lifting straps or other lifting equipment selected for use with these Lifting Points.</p>	Bore Size	Typical Lifting Provision	Load Rating lbf (kN)	4-8	2X 3/8-16UNC	2300 (10.6)	10	2X 1/2-13UNC	4300 (19.3)	12-20	2X 5/8-11UNC	6900 (30.7)	22-24	2X 3/4-10UNC	10000 (44.8)	26-28, 38	2X 7/8-9UNC	13800 (61.7)	30-36, 40-44	2X 1-8UNC	18300 (81.4)
Bore Size	Typical Lifting Provision	Load Rating lbf (kN)																				
4-8	2X 3/8-16UNC	2300 (10.6)																				
10	2X 1/2-13UNC	4300 (19.3)																				
12-20	2X 5/8-11UNC	6900 (30.7)																				
22-24	2X 3/4-10UNC	10000 (44.8)																				
26-28, 38	2X 7/8-9UNC	13800 (61.7)																				
30-36, 40-44	2X 1-8UNC	18300 (81.4)																				
4.3.8 Travel	<p>The range of travel is specified at order placement. Standard limits of travel distance are as follows:</p> <p>MINIMUM: 1 inch (25mm)*</p> <p>*Optional, adjustable stops can limit stroke below 1 inch. Refer to IOMS005 & IOMS006 for details on stops included valve stem connections.</p> <p>MAXIMUM: Length equal to 2 x Bore Size</p> <p>Consult ATI for applications with Travel > 2 x Bore Size.</p>																					
4.3.9 Bore Size & Thrust	<p>See IOMS 001 (ATI Linear Pneumatic Actuator Thrust Chart) for pneumatic cylinders from 4 inch to 44 inch diameter.</p> <p>Consult ATI for special constructions that exceed limits of the Thrust Chart.</p>																					



4.3.10 Pressure Connections	<p>1/4 NPT to 1-1/4 NPT, varies with Bore Size and order requirement</p> <table border="1" data-bbox="646 205 1312 453"> <thead> <tr> <th>Bore Size</th> <th>Standard *</th> <th>Common Options</th> </tr> </thead> <tbody> <tr> <td>4-7</td> <td>One (1) 1/4 NPT</td> <td>Two (2) 1/4 NPT</td> </tr> <tr> <td>8-10</td> <td>One (1) 3/8 NPT</td> <td>Two (2) 3/8 NPT</td> </tr> <tr> <td>12-30</td> <td>One (1) 3/4 NPT</td> <td>Two (2) up to 1-1/4 NPT</td> </tr> <tr> <td>32-44</td> <td>One (1) 1 NPT</td> <td>Two (2) up to 1-1/4 NPT</td> </tr> </tbody> </table> <p>* ATI will include 1, 2, or more, pressure connections meeting other thread specifications to accommodate customer requests.</p>	Bore Size	Standard *	Common Options	4-7	One (1) 1/4 NPT	Two (2) 1/4 NPT	8-10	One (1) 3/8 NPT	Two (2) 3/8 NPT	12-30	One (1) 3/4 NPT	Two (2) up to 1-1/4 NPT	32-44	One (1) 1 NPT	Two (2) up to 1-1/4 NPT
Bore Size	Standard *	Common Options														
4-7	One (1) 1/4 NPT	Two (2) 1/4 NPT														
8-10	One (1) 3/8 NPT	Two (2) 3/8 NPT														
12-30	One (1) 3/4 NPT	Two (2) up to 1-1/4 NPT														
32-44	One (1) 1 NPT	Two (2) up to 1-1/4 NPT														
4.3.11 Protective Coating	<p>The ATI standard protective coating includes surface degrease, surface abrasion, and 2 coats of an aliphatic polyurethane paint. The standard protective coating is applied to all environmentally-exposed carbon steel surfaces, with exception of the exposed portion of piston rods, threaded connections, and any threaded drive shafts (such as the ACME thrust shaft in the JS2 manual override). In some assemblies, the standard coating may also cover some stainless steel materials that are integral to the assembly of carbon-steel components.</p> <p>Consult ATI at time of order placement for specific details on the specification(s) to be used for protective coating(s).</p>															
4.3.12 Warranty	<p>Warranty terms and conditions are included in section 11 of this manual.</p> <p>ATI actuators are warranted against defects in material and workmanship for a period of two (2) years after the date of factory shipment. Refer to Product nameplate for serial number to confirm date of shipment.</p> <p>NON-WARRANTY CLAUSE: Contents of this publication are periodically checked for compliance with the associated Products, and corrections are made as necessary for subsequent publications. ATI also modifies the Product in this publication (within limits of Optional Certifications) to meet special requirements for specific customer orders. Therefore, ATI cannot exclude the possibility of discrepancies between this publication and the Product and special documentation that is prepared for a particular shipment, and ATI does not accept liability for discrepancies between information in this publication and the Product.</p>															



<p>4.3.13 Optional Certifications</p>	<p>When Certification is specified as an order requirement, ATI will manufacture using materials and specific design criteria defined for one or more of the following:</p> <ul style="list-style-type: none"> Pressure Equipment Directive (PED) 2014/68/EU  Notified Body No. 0035 Certificate # 01 202 USA / Q-12 4842 ATEX Group II Category 2 Gas & Dust   0035 II 2GD c TX Customs Union Technical Regulations (CU TR) 010/2011 & 012/2011   II Gb c T* X/ III Db c T* X <p><i>ATI L-series and HDL-series pneumatic linear actuators have been evaluated for ignition hazard and certified for CTR 012/2011 under “protection by constructional safety.” To ensure conformity with CU TR, only ATI parts and materials can be used.</i></p> <p><i>CU TR Notified Body: MinPromTest, Registration 1137746632726 Tel. +7(495)723.23.71, Other contact minpromtest.ru/rekvizity-kompanii</i></p> <p><i>Refer to product nameplate for production year of manufacture.</i></p>
--	---

5 Safety Warnings

THIS MANUAL COVERS GENERAL INSTRUCTIONS AND DOES NOT CLAIM TO ADDRESS ALL SAFETY FACTORS ASSOCIATED WITH ATI PRODUCTS OR THE ACCESSORIES THAT MAY BE MOUNTED TO ATI PRODUCTS. FOLLOWING THESE INSTRUCTIONS AND GUIDELINES WILL HELP IN PREVENTING PERSONAL INJURY, PROPERTY DAMAGE, AND DAMAGE TO THE PRODUCT.

ACTUATORS AND VALVES COME INTO CONTACT WITH CAUSTIC GASES AND FLUIDS IN MANY APPLICATIONS. AS A RESULT, ALL TOXIC OR FLAMMABLE FUMES MUST BE VENTED AND LIQUIDS MOVED TO A SAFE LOCATION TO ENSURE SAFETY.

5.1 Personnel Requirements

DO NOT INSTALL, OPERATE, OR MAINTAIN AN ATI PRODUCT UNLESS TRAINED AND QUALIFIED IN PRODUCT AND ACCESSORY INSTALLATION, OPERATION AND MAINTENANCE.

PROPER INSTALLATION OF THE PRODUCT IS CRITICAL TO PERFORMANCE AND SAFETY. DUE TO THE MANY VARIATIONS OF ACTUATORS, VALVES, AND RELATED CONTROLS, THE GENERAL INSTRUCTIONS IN THIS MANUAL MAY NOT ADDRESS SPECIFIC ISSUES AT A PARTICULAR INSTALLATION. EACH TECHNICIAN FOLLOWING THESE INSTRUCTIONS MUST BE COMPETENT, TRAINED, AND HAVE A WORKING KNOWLEDGE OF VALVES, VALVE ACTUATORS, ACTUATOR CONTROLS, AND THE SPECIFIC APPLICATION FOR THE INTENDED PRODUCT(S).

IT IS THE RESPONSIBILITY OF THE USER TO ENSURE PROPER SAFETY. ALWAYS TAKE NECESSARY PRECAUTIONS AND UTILIZE PROPER PERSONAL PROTECTIVE EQUIPMENT (PPE) WHEN DEALING WITH COMPRESSED GAS, PRESSURIZED HYDRAULIC FLUID, PINCH POINTS, AND ELECTRICITY. IT IS THE USER'S RESPONSIBILITY TO UTILIZE APPROPRIATE PROTECTION AGAINST HEARING DAMAGE WHEN WORKING NEAR THE ACTUATOR AND CONTROLS.



5.2 **Potential Hazards**

The Product has been designed in accordance with best practices for operational reliability, but as an industrial machine, it bears the risk of hazards if handled or operated improperly. Only trained, qualified personnel should work on or near the Product.

Some potential risks from installation include rigging & lifting. Risks during maintenance and operations include stored energy hazards, pinch points, overpressure conditions, and ignition hazards.

Rigging & Lifting

The Product includes a provision for lifting, refer to section 4.3.7. This provision does not address all possible assemblies that will include the additional weight of the valve and related controls. The user must ensure that the package weight including this Product does not exceed the rated limit of these lifting points. For cases where this limit is exceeded, the actuator and valve or other equipment must be rigged and lifted separately. Refer to rigging instructions in section 6.1 for lifting recommendations.

Before rigging, ensure the crane/hoist/rigging hardware lifting capacity can safely accommodate the desired load. Dropping the Product and any attached accessories or the attached valve may cause personal injury and/or equipment damage. For all mounting procedures, use adequately rated chain(s) & sling(s) with an adequately rated hoist or crane to lift and maneuver the Product. Use caution during lifting and handling to prevent uncontrolled movement or sudden shock loads.

Stored Energy Hazards & Noise

The Product is powered by supply pressure up to the maximum pressure defined in section 4.3.1. It is normal for actuator controls to permit a sudden release of this supply pressure. It is also required that this pressure be released before maintenance activities may begin on the Product. The release of pressure can produce excessive noise caused by sudden discharge at sonic velocity.

Depending on configuration of supply and exhaust lines during installation, this sudden pressure discharge may exhaust at the actuator. Users must be aware of exhaust lines and use appropriate personal protection equipment (PPE) to avoid injury from pressure discharge.

Exhaust port mufflers are optional accessories that may be used to disperse the pressure discharge and reduce noise. In some installations and control schemes, actuators may require exhaust port mufflers to reduce sound pressure levels at the point of exhaust below the limit of applicable codes. The use of a muffler is optional, and it must be properly selected and installed to avoid detrimental back pressure or other emission hazards.

Sharps & Pinch Points

Warning labels and tags located on the Products are made of metal foils that vary in thickness. Because the metal tags have sharp edges, personnel installing, handling, or working around the tags should protect against cuts or injury.

Actuators may be equipped with optional external stops and mechanical switch trip arms for controls accessories. During operation, sudden movements in actuator position can create a pinch-point hazard for personnel working very close to the Product.

Overpressure

The maximum supply pressure (MAWP) for the Product is defined in section 4.3.1. Whenever possible, actuators should be sized so that thrust at MAWP does not exceed MAST. For some applications, however, users may regulate supply pressure below MAWP to limit output thrust below the MAST of the valve or other connected equipment. Users must understand the limits of maximum thrust of the Product at MAWP as compared to the safe MAST value for connected equipment, and the user is responsible for ensuring that supply pressure is regulated, with safety relief valves if necessary, to limit Product maximum thrust to a safe value. Operating Product so that thrust exceeds MAST may cause permanent damage to connected equipment and void relevant warranties.

Ignition Hazard

Based on the Ignition Hazards Assessment conducted per EN13463-1 & EN 1127-1, ATI Linear Valve Actuators do not have any potential or effective ignition sources in normal operation or in the event of a malfunction due to application limitations, design inherent safety and materials of construction. This hazard analysis is specific to the actuator and does not consider the addition of optional accessories such as electronic positioners, transmitters or other control components.

6 Handling and Storage

6.1 Receiving the Product

Proper care and precautions should be taken when unloading and handling the actuator, especially when rigging and lifting. Ensure that the valve is not connected to the actuator.

- ATI recommends that the actuator be lifted using appropriately rated hoist rings threaded into the upper head, as shown in the diagram below. Swivel hoist rings are depicted only to distinguish type from typical shouldered eyebolts. Refer to 4.3.7 for load ratings of actuator lifting points. Do not exceed the load rating for the hoist rings selected for use with the actuator.

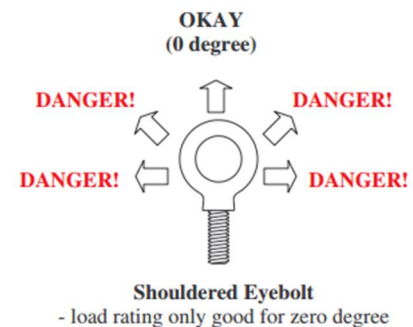
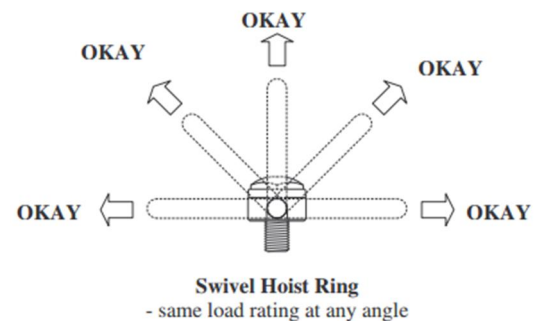
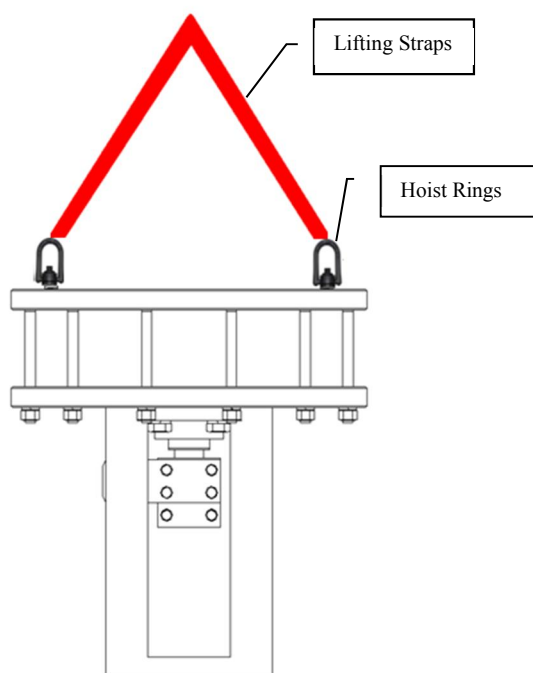

- Check that the actuator has not been damaged during transport.
- Check that the model, serial number and performance data on the data-plate match those in the order acknowledgement, test certificate and delivery note.
- Check that the fitted accessories comply with those listed in the order acknowledgement and the delivery note.
- For actuators shipped assembled to the valve, the settings of the mechanical stops and the settings of limit switches (if applicable) have been completed during assembly of the actuator to the valve. These settings should be checked before start-up and, if necessary, adjusted to requirements of the application.
- For actuators shipped separately from the valve, the settings of the mechanical stops and the settings of limit switches (if applicable) must be checked and adjusted while assembling the actuator onto the valve.



6.2 Storage and Preservation

ATI Products leave the factory in excellent working condition and with an excellent finish (these conditions are guaranteed by individual inspection certificates). To maintain these characteristics until the Product is installed, it is necessary to take appropriate measures during the storage period.

- Products contain resilient seals, and Products should not be stored in environments that are harmful to resilient seals.
- Plugs must be fitted in all ports for air connections, hydraulic connections, and cable entries. Plastic plugs are typically used to protect against the entry of foreign matter during transport, and these plastic plugs do not have a weatherproof function. If equipment is stored outdoors, the plastic protection plugs must be replaced by metal plugs to ensure weatherproof protection.
- If actuators are supplied separately from the valves, they must be placed onto a wooden pallet so as not to damage the coupling flange to the valve. In case of long-term storage, the coupling parts (e.g. flange and stem connection) must be coated with protective oil or grease to prevent corrosion, and any exposed shafts (e.g. piston rods) must be coated with protective oil to prevent corrosion of sealing areas during idle storage. If possible, cover the mounting flange with a protection disk, and store the actuator in the orientation intended for its use (e.g. store linear actuators in the vertical position).
- In case of long-term storage, it is advisable to keep the actuators in a dry place or to provide at least some means of weather protection. All plastic protection plugs must be replaced by metal plugs to ensure weatherproof protection. Care should be taken to plug all open ports to keep foreign particles and moisture from entering the Product.
- It is recommended that the actuator be periodically operated with filtered, dehydrated and lubricated air, at least once every 6 months for covered storage. Prior to operation, using a clean, soft cloth dampened with an appropriate oil-based solvent: Remove any dirt, dust, grease and/or other contaminants from exposed sealing surfaces. After such operations, apply rust preventative to exposed sealing surfaces, and carefully plug all the threaded connections of the actuator and controls (if existing).

7 Installation Instructions

7.1 Mount to Valve Body

Prior to assembly, inspect the actuator as described in section 6.1. Using a clean, soft cloth dampened with an appropriate oil-based solvent: Remove any dirt, dust, grease and/or other contaminants from exposed sealing surfaces (*i.e.* the exposed surface of the piston rod).

7.1.1 Vertical Mount on Valve

The stem coupling connection with the actuator determines the best method for installing an actuator to a valve. Refer to IOMS005 and IOMS006 for instructions specific to each coupling configuration (HD Threaded Coupling and Split Coupling, respectively). For other actuator configurations, refer to instructions in IOM1001 or IOM1002—linear actuators for spring return extend (SRE) and spring return retract (SRR) service.

The instruction that follows is one option typical for assembling a linear actuator to a rising-stem valve in on/off service using an HD Threaded Coupling described further in IOMS005. This instruction assumes the actuator is required to extend to close the valve and retract to open the valve.

Refer to the sketch in “Appendix A – Exploded View of Linear Actuator” for the parenthetical references that follow in this section.

1. Position the subject valve to the full closed position (tight shut off).
2. Remove the valve hand wheel and hand wheel drive assembly. (See valve manufacturer’s assembly/disassembly instructions).
3. Position the actuator in the full closed (piston rod (Item 1) fully extended) position.



4. Remove the coupling block assembly (Item 2) by removing the coupling block bushing retaining cap screw and lock washer (Items 3 & 4) from the coupling block.
5. Remove the pin spanner wrench (Item 5) from inside the adaption bracket.
6. Position spanner wrench (Item 5) in holes located in the coupling block bushing (Item 6) and turn counter clockwise until completely out of the coupling block. It is not necessary to remove the piston rod insert (Item 7) or set screw (Item 8).
7. Position the actuator in the full open position.
8. Remove position indicator guide, screws, and lock washers (Items 9, 10 & 11).
9. Remove position indicator and stud (Items 12 & 13).
10. Position actuator and adaption bracket to final adaption or valve as per application. Attach with appropriate fasteners to recommended torque specs.
11. Position coupling block assembly over valve stem and thread on clockwise for right hand threads or counter clockwise for left hand threads. Thread down on valve stem until bottom of coupling block assembly is within 1/8" to 1/4" of the bottom of the adaption bracket. It is not necessary to remove threaded insert (Item 15).
12. Align the coupling block assembly to locate the position indicator hole with centerline of the adaption bracket.
13. Position the actuator in the full closed position (piston rod (Item 1) fully extended) position very slowly to install piston rod into the coupling block assembly.
14. Reinstall coupling block bushing (Item 6) with pin spanner wrench (Item 5). NOTE: DO NOT FULLY TIGHTEN UNTIL STEP 16 IS COMPLETED.
15. Reinstall position indicator and stud (Items 12 & 13).
16. Reinstall position indicator guide, screws, and lock washers (Items 9, 10 & 11).
17. Tighten coupling block bushing (Item 6) with pin spanner wrench (Item 5), then install coupling block bushing retaining cap screw and lock washer (Items 3 & 4).
18. Cycle actuator and check for full open and full close. Adjustment may be necessary by repositioning the stop adjustment bolts (Item 14).
19. Reinstall pin spanner wrench on inside adaptation bracket.

7.1.2 Horizontal Mount with Valve

ATI recommends that a Pneumatic Double Acting (DA) Linear Actuator be installed in the vertical orientation, with the actuator travel perpendicular to grade, to ensure long life with minimal maintenance of dynamic piston seals and bearings.

Special care must be taken when orienting a linear actuator for service in a horizontal position (where actuator travel is horizontal to grade). To avoid cantilever loads on the valve stem and adaption bracket, it is the customer's duty to ensure proper support for the horizontal actuator. Proper support includes ground support and/or ceiling suspension at the actuator center of mass or at both ends of the actuator.

7.2 Connection to Valve Stem

Refer to IOMS005 and IOMS006 for common stem coupling configurations (HD Threaded Coupling and Split Coupling, respectively).



7.3 **Setting the Stroke Length**

WARNING: Actuators may be equipped with optional external stops and mechanical switch trip arms for controls accessories. During normal operation, movements in actuator position can create a pinch-point hazard for personnel.

Refer to IOMS005 and IOMS006 for additional details specific to each coupling configuration (HD Threaded Coupling and Split Coupling, respectively). For other actuator configurations, refer to instructions in IOM1001 or IOM1002—linear actuators for spring return extend (SRE) and spring return retract (SRR) service.

The instruction that follows is one option, typical for assembling a linear actuator to a rising-stem valve in on/off service using an HD Threaded Coupling described further in IOMS005. This instruction assumes the actuator is required to extend to close the valve and retract to open the valve, and this instruction assumes that external stops were included with the stem coupling and actuator.

Refer to the sketch in “Appendix A – Exploded View of Linear Actuator”, items 2 & 14, for the references in this section to travel stops and actuator stem coupling.

To set the retract stop position (valve full open): Adjust the upper travel stop screws in the actuator stem coupling so that the valve is fully open as the actuator reaches the up stop position.

For many valve configurations and for applications that prohibit external stops, it is possible to eliminate the external open (up) travel stops and install the ATI Linear Actuator so that the upper head of the power cylinder acts as an internal stop for the actuator piston in the full open (retract) position.

To set the extend stop position (valve full close): The setting of the closed valve position is performed by adjusting the lower travel stop screws in the actuator stem coupling. For many valve configurations and applications, it is possible to use the valve seat as the stop. The external stops are set approximately 1/4 turn to 1/2 turn gap between the stop the lower plate, to ensure the valve seals, with the stops acting as protection against over-travel.

7.4 **Setting the Stroke Time**

Stroke time is not adjustable at the pneumatic actuator. The operating speed of the actuator is fixed by the size and number of supply/exhaust ports included for the order.

If the actuator is purchased with an optional hydraulic override or with an optional hydraulic snubber, then speed control valves in the hydraulic circuit may be adjusted to dampen sudden movements to the pneumatic actuator due to process conditions. Refer to IOMS003 or IOMS008 for details on installation and operation of a Hydraulic Override or Hydraulic Snubber.

For pneumatic actuators without hydraulic options, stroke time may be adjusted by a modification to the control circuit for the actuator. To accelerate stroke speed, air must either be supplied at a faster rate, or air must be exhausted at a faster rate. For assistance in adjusting speed of an automated valve, or for any stroke speed faster than 0.5 seconds per inch of travel, contact ATI or your local automation specialist.



8 Preparation for Start-up

8.1 Pneumatic Connections

Connect the pneumatic supply and exhaust lines to the actuator and controls using fittings and/or pipes in accordance to site specifications. Connection must be sized appropriately to ensure necessary flow rate of air to the actuator. Piping must be suitably fastened so as not to cause excessive stress or cause the threaded connections to loosen if the system undergoes strong vibrations.

IMPORTANT: Every precaution must be taken to ensure that any solid or liquid contaminants that may be present in pneumatic fill lines and pipework are removed before connection and pressurization, to avoid possible damages or other loss of performance to the Product.

An air filter with an automatic drain is recommended to maintain a dry and contaminate free air supply to the actuator. If the actuator is to be cycled more than 10 times a month, an oil lubricator is recommended.

The inside of the pipes used for the connections must be cleaned before use. Wash them with suitable substances and blow through them with air or nitrogen. The ends of the tubes must be de-burred and cleaned.

Once the connections are completed, operate the actuator and check that it functions correctly, that the operation times meet the plant requirements and that there are no leakages in the pneumatic connections.

8.2 Electrical Connections

The standard Pneumatic Double Acting (DA) Linear Actuator does not have electrical connections, but optional accessories may be included that require electrical connection.

Connect the electrical feed, control and signal lines to optional accessories of the actuator by linking them with the terminal blocks of the electrical components. In order to do this, the housing covers must be removed without damaging the coupling surfaces, the O-rings or the gaskets. Follow the installation instructions for each accessory.

For electrical connections, use components (cable glands, cables, hoses, conduits), that meet the requirements and codes applicable to the plant specifications (mechanical protection and/or explosion-proof protection). If conduits are used, it is advisable to carry out the connection to the electrical enclosures by inserting flexible conduit so as not to cause anomalous stress on the housing cable entries.

Replace the plastic plugs of the unused enclosure entries with metal plugs, to guarantee weatherproof tightness and to comply with the explosion-proof protection codes (where applicable).

After connections are complete, check that the controls and signals work properly. Ensure that the actuator piston rod extends/retracts/fails in place, as appropriate, upon loss of supply pressure or loss of control signal.

8.3 Start-up

Prior to start-up in hazardous areas, ensure that the Product and all accessories are certified for the risk of ignition hazard at the site.

During start-up, ensure that all accessories are properly connected and calibrated for use, as follows:

1. Check that the pressure and quality of the power supply (filtering degree, dehydration) are as prescribed. Check that the feed voltage values of the electric components (solenoid valve coils, micro-switches, pressure switches, etc.) are as prescribed.
2. Check that the actuator controls work properly (remote control, local control, emergency controls).
3. Check that the required remote signals (valve position, air pressure, etc.) are correct.



4. Check that the setting of the actuator control unit components, (pressure regulator, pressure switches, flow control valves, etc.) meet site requirements.
5. Check that there are no leaks in pneumatic connections.
6. In accordance with the applicable protective coating specification(s), repair any protective coating that has been damaged during transport, storage or assembly.

9 Maintenance

For Troubleshooting an ATI Pneumatic Double Acting (DA) Linear Actuator, refer to IOMS007.

9.1 Safety Reminder

IMPORTANT: BEFORE CARRYING OUT ANY MAINTENANCE OPERATION, IT IS NECESSARY TO ISOLATE PNEUMATIC FEED LINES AND EXHAUST ALL PRESSURE FROM THE ACTUATOR AND ALL CONTROL MANIFOLDS AND VESSELS, TO ENSURE SAFETY OF MAINTENANCE STAFF. ENSURE THAT ANY ELECTRICAL CONNECTIONS TO ACTUATOR CONTROLS ARE DE-ENERGIZED. IF PRODUCT OPERATION IS REQUIRED FOR TROUBLESHOOTING OR PARTIAL STROKE TESTING, THE MAINTENANCE PERSONNEL MUST ENSURE THAT ELECTRICAL AND PRESSURE CONNECTIONS ARE IN A CONTROLLED STATE (LOCKOUT/TAGOUT) FOR SAFE OPERATION.

9.1.1 Routine Maintenance

ATI actuators have been designed to work for long periods in the harsh conditions with minimal maintenance. As with any mechanical equipment, the service interval is determined by stroke frequency, environmental conditions, and other conditions of use. The customary service interval for routine maintenance is one (1) to five (5) years. More frequent service may be required.

It is advisable to periodically check the actuator as follows:

1. Check that the actuator operates the valve correctly and with the required operating times. If the actuator operation is infrequent, carry out a few opening and closing operations with all existing controls (remote control, local control, emergency controls, etc.), if site conditions allow.
2. Check that the signals to the remote control device are correct.
3. Check that the air supply pressure value is within the required range.
4. If there is an air filter in the pneumatic control circuit, disassemble the cup periodically and wash it with soap and water. Disassemble the filter. If this is made up of a sintered cartridge, wash it with nitrate solvent and blow through with air. If the filter is made of cellulose, it must be replaced when clogged.
5. Check that the external components of the actuator are in good conditions.
6. Check the protective coating of the actuator. If some areas are damaged, repair the protective coating according to the applicable specification.
7. Check that there are no leaks in the pneumatic connections.
8. Check that there are no leaks into the actuator housing, (oil, water, etc.); by removing the inspection plug located in the actuator housing cover.

9.1.2 Replacing Seals

Refer to the sketch in "Appendix B – Seal Maintenance" for the parenthetical references that follow in this section.

If there are leaks in the cylinder or a malfunction in the mechanical components, or in case of scheduled preventive maintenance, the actuator must be disassembled and seals must be replaced.

The Standard contents in the ATI Maintenance Seal Kit for linear actuators are listed below. If additional seals are required for a customized design, they will be provided with the ATI Maintenance Seal Kit for the actuator serial number.



Manufacturer's Maintenance Seal Kit

Item # (App. B)	Description	Qty
2	O-ring	1
4	Wear Band	1
5	Piston Quad Seal	1
7	O-ring	1
9	O-ring	1
14	O-ring	1
16	Wiper Ring	1
18	Bearing Quad Seal	1

The instruction that follow is applicable for seal replacement in a standard linear pneumatic, double acting (DA) actuator. For other configurations, refer to instructions in IOM1001 or IOM1002—linear actuators for Spring Return Extend (SRE) and Spring Return Retract (SRR) service.

1. Before rigging, ensure the crane/hoist/rigging hardware lifting capacity can safely accommodate the desired load.
2. Thread swivel hoist rings into upper head.
3. Detach the actuator from the valve, remove swivel hoist rings, and place actuator upside down on a disassembly platform with the piston rod pointed up.
4. Loosen the tie rod nuts (Item 13) in a criss-cross pattern.
5. Remove tie rod nuts and lock washers (Items 12 & 13).
6. Thread swivel hoist rings into lower head (Item 10) and attach rigging straps.
7. Lift lower head (Item 10) off of actuator with crane and place on a flat surface.
8. Remove retaining ring (Item 17), and extract rod bearing (Item 15) from lower head (Item 10).
NOTE: If seal maintenance is limited to this bearing, refer to an abbreviated procedure in IOMS009.
9. Remove wiper ring (Item 16), O-ring (Item 14), and quad seal (Item 18) from the rod bearing (Item 15).
10. Clean the rod bearing (Item 15) with a light degreaser.
11. Lightly grease the new bearing O-ring and quad seal (Item 14, 16) and install on rod bearing (Item 15).
12. Without grease, install the new wiper ring (Item 16) on the rod bearing (Item 15).
13. Flip lower head (Item 10) so that the O-ring side is facing up. Remove O-ring (Item 9) and clean the groove with a light degreaser.
14. Lightly grease new O-ring (Item 9) and install on lower head (Item 10).
15. Remove tie rods (Item 11) from upper head (Item 1).
16. Thread lifting eye or swivel hoist ring into/onto the end of the piston rod (Item 8) and attach rigging straps.
17. Lift piston assembly (Item 8, 6) out of the cylinder tube (Item 3) and place on a flat surface.
18. Remove wear band (Item 4) and quad seal (Item 5) from piston (Item 6).
19. Thread locking compound is applied to the threads by the manufacturer during initial assembly. As a result, disassembly will require heating to loosen the thread locking compound. To remove the piston rod seal (Item 7), heat the piston assembly using a torch and unthread piston rod (Item 8) from piston (Item 6).
20. After the piston rod has completely cooled, remove piston rod seal (Item 7).
21. Clean the piston rod seal groove with a light degreaser.
22. Lightly grease the piston rod seal (Item 7) and install the seal on piston rod (Item 8).



23. Clean piston assembly seal grooves. Install new lightly greased quad seal to piston (Item 6).
24. Without grease, trim to length and then install new wear band (Item 4).
25. Attach lifting hardware and rigging straps to cylinder tube (Item 3). Take extra precaution to avoid scarring the inner diameter of the metal cylinder tube. Lift cylinder vertically and place on a flat surface.
26. Remove O-ring (Item 2) from the upper head (Item 1). Clean seal groove.
27. Install lightly greased O-ring (Item 2) to upper head (Item 1) seal groove.
28. Reassemble actuator in reverse order of disassembly.

9.2 Lubricating Mechanism

For normal duty, the actuator is lubricated for the life of the Product.

In case of high load and high frequency of operation it may be necessary to periodically restore the lubrication inside the cylinder. For this operation it is necessary to disassemble the actuator. Follow the instructions for seal maintenance to disassemble the Product. Clean all metallic surfaces of old grease and any contaminants, then apply a thin coating of new grease on the contact surfaces between each cylinder and piston and between the cylinder bushing(s) and piston rod(s).

The following greases are used by ATI for standard working temperature and are suggested for re-lubrication:

MANUFACTURER	JET LUBE	DUBOIS
TYPE	ACTUATOR GREASE	LUBRIPLATE MPG-2
COLOR	BEIGE / AMBER	GREEN
VISCOSITY AT 40°C	68 cSt	428 cSt
FLASH POINT	507 °F / 264 °C	420 °F / 216 °C
DROP POINT	536 °F / 280 °C	500 °F / 260 °C

Use of other greases may be suitable if proven compatible with seal specification in the actuator. Consult ATI with questions on alternative greases.

The use of lubricated air is optional, and generally acceptable for the Product. Use of lubricated air may extend the working life of seals and allow for longer intervals between scheduled maintenance. The user is responsible for selecting lubricator oil that is compatible with all exposed seals in the system, and the user must maintain the lubrication system to filter contaminants and to filter exhaust emissions.

The following lubricator oil is optional, and suggested for oil lubrication for common Product seal types listed in section 4.3.2:

MANUFACTURER	EXXONMOBIL
TYPE	VELOCITE OIL NO. 10
VISCOSITY @40°C	21 cSt
FLASH POINT	345 °F
DROP POINT	-5 °F

9.3 Parts Ordering

In correspondence with ATI or your local ATI Authorized Representative, include the serial number from the ATI actuator nameplate. If documentation from the original order is available, include the ATI part number from the ATI Order Acknowledgement or ATI Shipping Documents.

Warning: To ensure compliance to certification requirements, use only genuine ATI replacement parts. Rebuilding an ATI Product with components that are not supplied by ATI may void the Product warranty, void the Product Certification, adversely affect Product performance, and/or cause personal injury and property damage.



10 Disposal

At the end of its functional life, users may carry out recycling or disposal of the Product and its accessories using these instructions as a guide.

1. Any disposal or recycling must be performed according to site requirements and local regulatory requirements.
2. It is the user's responsibility to ensure Product is safely depressurized and that cleaning and disposal of any fluids is performed in accordance to local regulations. Pneumatic actuators are lubricated internally with grease, which will separate into oil and its base soap over time. In some applications, the Product may have been in contact with caustic gases and fluids, which must be cleaned prior to Product disposal.
3. Product may be dismantled for part sorting. Read and follow the appropriate Product and accessory manual(s) before dismantling. Observe all warning instructions marked on the Product(s) and in the manual(s).
4. Sort dismantled parts according to their material. A majority of the material in the Product, more than 98% by weight, can be recycled. Forward sorted parts according to local practice for recycling or disposal.

Materials of construction may be noted in order documentation. If a list of materials is not available, the metal components may be sorted by using a magnet to inspect for ferrous content, as follows:

- Carbon steel may be recycled: Majority of material is carbon steel, ~90% by weight. Carbon steels are ferrous and will hold a magnet.
- Stainless steel may be recycled: Some materials, fittings and many fasteners are stainless steel, typically 300 series, which will not hold a magnet.
- Bronze may be recycled: Bearings are often made of bronze / brass. This material is dark yellow in color with perhaps a green oxide, and it is non-ferrous and will not hold a magnet.
- Aluminum may be recycled: Some special Product constructions many optional accessories contain aluminum components, less dense and lighter in weight than stainless steels, also non-magnetic.
- Plastic may be sorted for recycling or discarded with mixed waste: Optional accessory covers and some position indicators are made of plastic.
- Electronics must be disposed according to local regulations. Optional valve controllers, positioners, transmitters and some other electronic components are manufactured with solder and capacitors that can be harmful if allowed to leach into the environment. Recycling and disposal of electronics must be done according to applicable regulations.
- Soft parts—elastomeric seals, engineered (PTFE) seals and some bearings throughout the assembly—are not recyclable. Soft goods that have been cleaned of caustic fluids may be discarded with mixed waste.

If local requirements disallow sorting for recycling or other disposal, contact ATI about returning Product to the manufacturer for recycling. ATI will only accept devices that have been cleaned of any caustic fluids, and a fee will be charged for labor and handling of the produce.



11 Terms and Conditions/Warranty

Except as otherwise expressly agreed to in writing by an authorized representative of Automation Technology, LLC. (hereinafter "ATI"), the following terms and conditions (these "Terms and Conditions") shall apply to all offers for the purchase or sale of products manufactured or supplied by ATI under brand names including, but not limited to "ATI", "Gevalco", etc.

- A. **CONDITIONAL ACCEPTANCE; REJECTION OF PURCHASER TERMS** – All orders and acknowledgements of Purchaser shall constitute only consent to these Terms and Conditions and a representation that Purchaser is solvent. All quotations and offers of sale by ATI are expressly limited to these Terms and Conditions and are subject to written acceptance by ATI. Any such acceptance by ATI is expressly conditioned upon assent of Purchaser to these Terms and Conditions, and ATI hereby expressly objects to and rejects as material alterations to these Terms and Conditions any terms or conditions of Purchaser, whether contained in Purchaser's order, acknowledgement or otherwise, that are different from or in addition to these Terms and Conditions.
- B. **PRICES** - ATI quotations are valid for thirty (30) days from date of issuance, unless otherwise stated by ATI in writing, and are subject to withdrawal or change at any time prior to acceptance by ATI. Prices are ex works, in United States Dollars, and firm for thirty (30) days from date of ATI's written acceptance of Purchaser's order and an unconditional authorization for the immediate manufacture based on customer supplied information. If for any reason authorization does not commence within such thirty (30) days, prices in effect at the time of release for manufacture will apply, unless otherwise stated in writing. All sales, use, excise, value-added, import, export and other taxes, duties, customs and the like (collectively "Taxes") are the responsibility of Purchaser and will be added to the price to the extent that ATI pays on Purchaser's behalf or is required by law to pay in connection with the sale. ATI reserves the right to invoice and be paid for any Tax at the time of shipment or any time thereafter. All orders are subject to laws and regulations that are in effect and that become effective prior to delivery. Typographical or clerical errors in quotations, orders and acknowledgements are subject to correction by ATI. Prices do not include installation or any other service, unless so stated expressly in the quotation or ATI's order acknowledgement. Prices include one (1) copy of any applicable manuals. Any additional manuals or other printed materials requested by Purchaser are subject to additional cost, to be quoted at or near the time that such materials are requested by Purchaser.
- C. **PAYMENT** - Payment from Purchaser is due within thirty (30) days from date of first invoice, unless otherwise stated on ATI's quotation or order acknowledgement. For international orders, ATI reserves the right to require, before commencing filling the order, security in the form of a letter of credit or the like, in a form and from a bank or guarantor acceptable to ATI. Subject to any applicable usury law that would void or render invalid or unenforceable this sentence, in which case the specified rate will be deemed to be reduced to the maximum allowed by law, simple interest at the rate of 1.5 percent per month will apply to balances unpaid within 30 days from date of first invoice. ATI will invoice upon making available for shipment. ATI reserves the right to payment and Purchaser will be responsible for any cost associated with storage of products or delay in making products available for pickup that occurs at the request of Purchaser.
- D. **FORCE MAJEURE** – In no event shall ATI be liable for non-delivery or delay in delivery, or for failure or delay in the performance of any obligation contained herein, that arises directly or indirectly from acts of God, unforeseeable circumstances, acts (including delays or failure to act) of any governmental authority (de jure or de facto), war (declared or undeclared), terrorism, riot, revolution, priorities, fires, floods, weather, strikes, labor disputes, sabotage, epidemics, factory shutdowns or alterations, embargoes, delays or shortages in transportation, delay in obtaining or procuring or inability to obtain or procure labor, materials or manufacturing facilities, delay in obtaining or inability to obtain timely instructions or information from the Purchaser, or any other cause or circumstance of any other kind beyond ATI's reasonable control. The foregoing provision shall apply even though such causes or circumstances may occur after ATI's performance has been delayed for other causes or circumstances.
- E. **SHIPPING** – (a) Products are sold ex works. Risk of loss is the responsibility of and title transfers to Purchaser once products are made available at Seller's facility for pickup by Purchaser or its carrier.
- (b) Acknowledged ship dates represent the estimated date of availability for pickup, rather than actual shipment or delivery at destination for which Purchaser is responsible. All indicated shipping dates are estimates, based on prompt receipt of all necessary information from Buyer necessary to process the order. ATI will use its best reasonable efforts to make products available for pickup by such dates, but there is no guarantee to do so. Indicated time periods for pickup availability are estimated from the latest to occur of: 1) ATI's acceptance of Purchaser's order, 2) ATI's receipt of valve dimensional information, if applicable, 3) ATI's receipt of Purchaser supplied components required to manufacture or supply the products, if applicable, or 4) ATI's receipt of drawings approved by Purchaser. Products ordered on an "in stock" basis are subject to prior sale to other customers. Acknowledged ship dates are subject to changes caused by additions to or modification of the original order agreed to by both Purchaser and ATI.
- (c) Under no circumstances shall ATI have any liability whatsoever for loss of use or for any indirect or consequential damages as a result of delayed delivery.
- (d) Purchaser is responsible for payment of carrier and all other shipping costs and for making all arrangements necessary for pickup, transport, export, import and delivery to Purchaser's destination. Without prejudice to any ex works rights of ATI and obligations of Purchaser, Purchaser consents in advance to ATI shipping collect any products that Purchaser fails to pick up, and Purchaser will remain responsible for all associated pickup, transport, export, import and delivery costs, including any unknown to ATI or Purchaser at the time of shipment.
- F. **DESIGN** - Due to continuous product development, ATI reserves the right to modify designs, materials and specifications without prior notice.



- G. CANCELLATION - Orders acknowledged by ATI are not subject to cancellation or suspension except with the advance written consent of ATI and upon terms which will compensate ATI for and indemnify ATI from and against loss or damage occasioned by such cancellation or suspension, including without limitation for all costs and expenses already incurred or commitments made by ATI in connection with the processing, purchasing, handling, and fabrication of equipment for the order and a reasonable profit thereon. ATI's determination of such termination charges shall be conclusive.
- H. INSPECTION - Final inspection and acceptance of products must be made at ATI's facility and shall constitute a waiver by Purchaser of any claim for loss or damage, except for latent defects not reasonably discoverable by such inspection. Purchaser's representative may inspect products during normal business hours and must do so in a manner that does not interfere with ATI operations.
- I. ATI WARRANTY; EXCLUSIVE PURCHASER REMEDY – All products manufactured by ATI are warranted against defects in material and workmanship for a period of two (2) years after the date that the products were made available for pickup by Purchaser. ATI's warranty excludes any defects resulting from improper or abnormal shipping, operation or maintenance. Purchaser must immediately, and in no event later than thirty (30) days after becoming aware of a suspected defect, notify ATI in writing of any such suspected defect. Within a reasonable time following ATI's receipt of such notice, investigation and confirmation of a defect, ATI will have the right and the obligation, in its sole discretion, to repair at no cost to Purchaser such defect or replace the defective product or component thereof with a non-defective product or component thereof. Repair or component replacement by non-ATI authorized agents WILL VOID all remaining warranty on the product. Products purchased by ATI from a third party for resale to Buyer ("Resale Products") shall carry only the warranty extended by the original manufacturer. ATI's repair or replacement obligations under this Paragraph I do not extend to any labor or other loss or damage occasioned by, incidental to, or in consequence of any such defect. Purchaser's sole and exclusive remedy and ATI's obligation and liability for breach of warranty are expressly limited to such repair or replacement. Goods repaired or replaced during the warranty period shall be in warranty for the remainder of the original warranty or ninety (90) days, whichever is longer. All other remedies of Purchaser are hereby expressly excluded. THE WARRANTY CONTAINED IN THIS PARAGRAPH I IS THE SOLE AND EXCLUSIVE WARRANTY PROVIDED BY ATI WITH RESPECT TO ITS PRODUCTS AND SUPERSEDES AND IS IN LIEU OF ANY AND ALL OTHER WARRANTIES, WHETHER EXPRESS, IMPLIED, STATUTORY OR OTHERWISE, INCLUDING WITHOUT LIMITATION ANY IMPLIED WARRANTY OF MERCHANTABILITY OR FITNESS FOR PARTICULAR PURPOSE, ALL OF WHICH ARE HEREBY EXPRESSLY DISCLAIMED. Purchaser acknowledges and agrees that ATI Manuals, printed materials and any other documentation do not constitute warranties of any kind, including with respect to quality or performance. Purchaser is expected to determine the suitability of ATI products for ordinary and Purchaser's particular purposes.
- J. EXCLUSION OF CONSEQUENTIAL DAMAGES; LIMITATION OF DIRECT DAMAGES - ATI shall not be liable for and Purchaser shall have no right to recover from ATI for any indirect, special or consequential damages, even if ATI has actual notice of any special circumstances from which any such damages might arise. Moreover, subject to Paragraph I which would completely bar any such recovery of direct damages if ATI honors its warranty, in no event shall any recovery of direct damages against ATI exceed the amount of the order price attributable to the portion of the product or products that is determined to have caused any alleged loss, damage or injury that is compensable under these Terms and Conditions and not remedied by ATI.
- K. RETURNS – No product may be returned for credit or adjustment without written permission and tagging instruction from ATI. Upon receipt of approved returns, any handling/restocking charges and/or cost to recondition for resale, will be the responsibility of Purchaser.
- L. GOVERNING LAW; VENUE AND JURISDICTION - All sales of products by ATI and any disputes arising out of or related to such sales or products or these Terms and Conditions shall be governed by, and these Terms and Conditions shall be construed in accordance with, the laws of the State of Texas, without regard to its conflicts of law principles that would apply the law of another jurisdiction. The United Nations Convention on Contracts for the International Sale of Goods is expressly disclaimed by and excluded from these Terms and Conditions. ATI's offer of sale may only be accepted in Harris County, Texas and any resulting contract is performable in whole or in part in Harris County, Texas. Venue for any litigation arising out of such sale, products or contract shall be proper in the state or federal district courts of Houston, Harris County, Texas, U.S.A., to the exclusive jurisdictions of which Purchaser hereby expressly submits.
- M. NON-WAIVER – Any waiver by ATI of any breach of any of these Terms and Conditions must be set forth in a writing signed by an authorized representative of ATI and shall not constitute a waiver of or otherwise prejudice ATI's right to demand strict performance of any other term or condition of these Terms and Conditions.
- N. REMEDIES CUMULATIVE – ATI's remedies pursuant to these Terms and Conditions and applicable law are cumulative in nature and election or pursuit of any such remedy shall not prohibit ATI from electing or pursuing any other such remedy.
- O. SEVERABILITY – In the event that any provision or portion of any provision of these Terms and Conditions is held void, invalid or unenforceable, such void, invalid or unenforceable provision or portion thereof shall be deemed severed from these Terms and Conditions, and the balance of these Terms and Conditions shall remain in full force and effect.
- P. EXPORT / IMPORT - Buyer agrees that all applicable import and export control laws, regulations, orders, and requirements, including without limitations those of the United States will apply to the receipt and use of the Goods and Services provided by ATI. In no event shall Buyer use, transfer, release, import, export, re-export Goods in violation of such applicable laws, regulations, orders, or requirements.
- Q. BUYER SUPPLIED DATA – To the extent that Seller has relied upon any specification, information, representation of operating conditions or other data or information supplied by Buyer to ATI, in the selection, or design of the Goods and the preparation of ATI's quotation, and in the event that actual operating conditions or other data differ from those represented by Buyer and relied on by ATI, any warranties or other provisions contained herein are null and void. To the degree such data errors cause re-design or re-manufacture of the Goods, Buyer shall be responsible for additional costs incurred by ATI.



12 Revision Record

Refer to the NON-WARRANTY CLAUSE in section 4.3.12.

Rev #	Issue Date	Description	Reviewed By & Date	Approved By & Date
I.R.	8/20/2010	Initial Release	Aneil A. 8/19/2010	Shane M. 8/20/2010
A	8/24/2010	Horizontal installation statement added. ECO # 10050	Aneil Ali, 8/24/10	Shane M., 8/27/10
B	3/14/2012	Revised Terms and Conditions. Added HDL JS2 installation instructions.	Aneil Ali, 2/26/12	M. Anderson, 3/14/2012
C	8/04/2014	Updated Section 1.4 Receiving/Lifting to recommend the use of hoist rings for the lifting of DA and SRR actuators (per ECN# 741)	J. Pollard, 8/4/14	D. Rojas, 8/4/14
D	7/01/2015	This replaces revisions C of IOM1003 & IOM1011. Clerical updates and sections reordered to align format with other IOM's. Sections added to 4.3, section 10 added, and other language added throughout the document in response to 3 rd party comments during CU TR certification. Some sections added to 4.3 to align with ISO 4414 requirements for pneumatic systems.	D. Richardson, D. Rojas 6/23/15 J. Pollard 6/29/15	D. Leese 7/01/15
E	8/06/2015	Update 4.3.2 for temperature ratings. Minor clerical changes throughout following IOM1001/1002 update. ECN # 00952.	D. Richardson, D. Rojas 8/06/15	D. Leese 8/06/2015
F	12/21/2015	Update 9.2 grease table.	D. Rojas 12/21/15	D. Leese 12/21/15
G	11/6/2017	Updated PED Directive number to 2014/68/EU	W. Turner 11/6/17	D. Rojas 11/6/17

APPENDIX A – EXPLODED VIEW OF LINEAR ACTUATOR

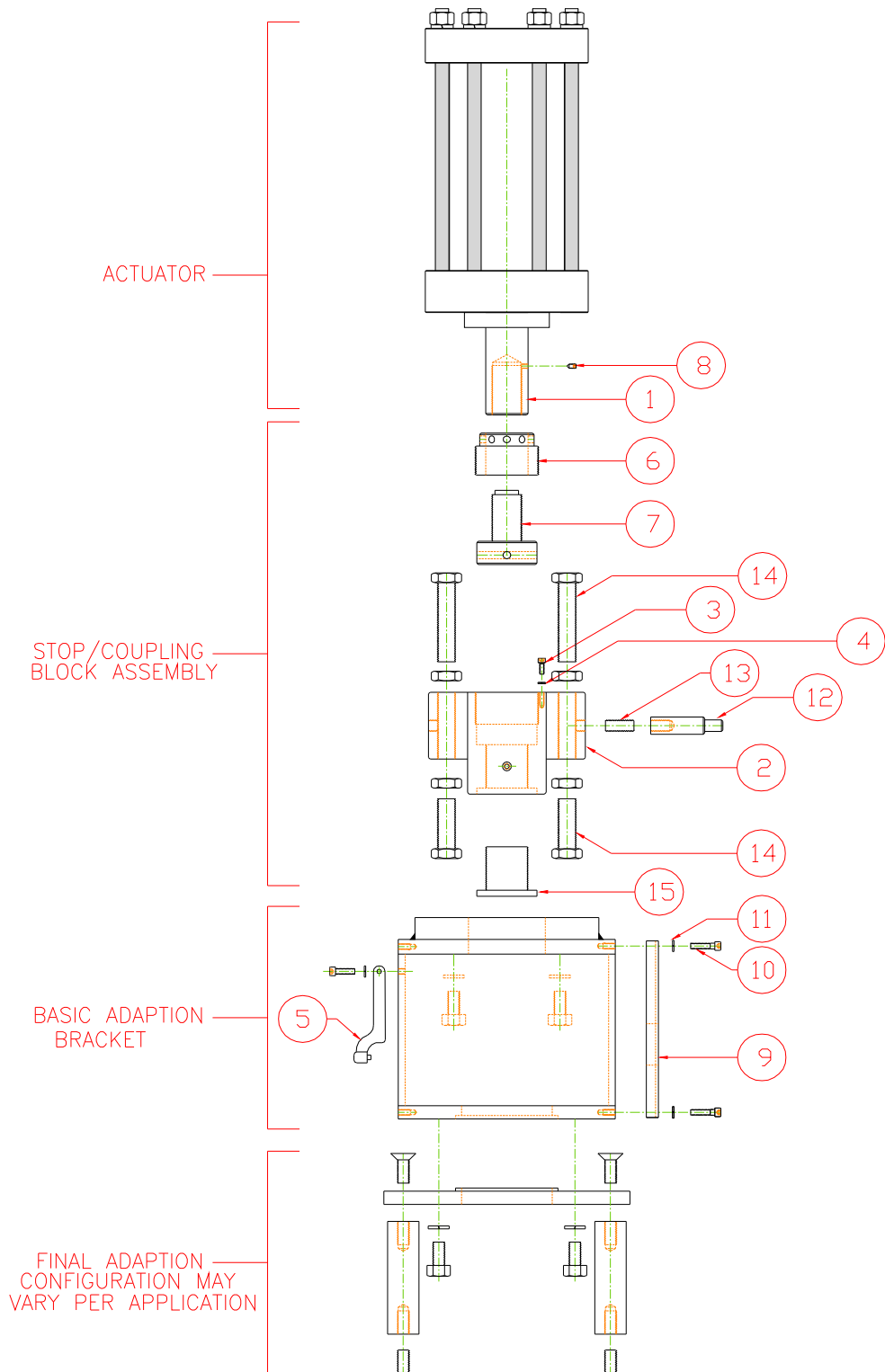

APPENDIX B – SEAL MAINTENANCE

Adapted from Drawing 1245

