

# INSTALLATION, OPERATION & MAINTENANCE MANUAL

## Hydraulic Spring Return Retract (SRR) Linear Actuators

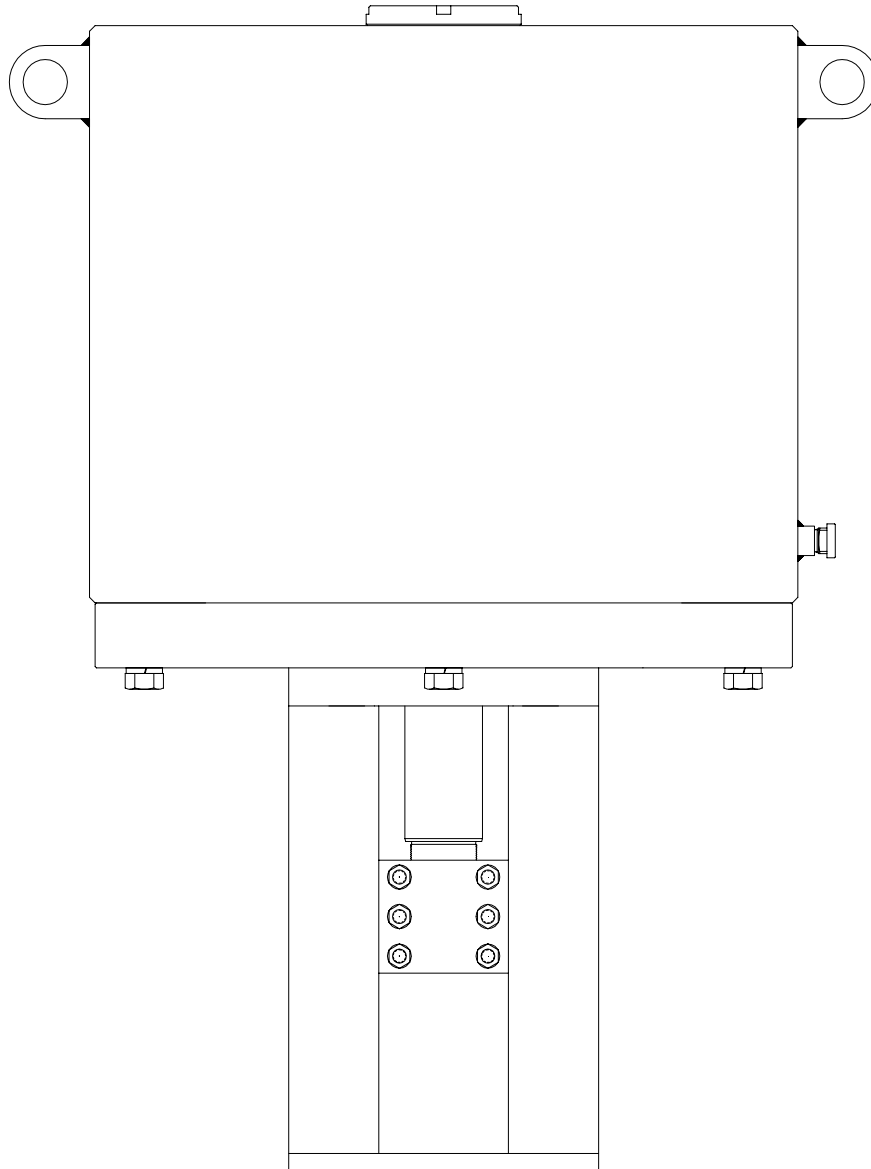

*The Severe Service Standard in Valve Automation*

Automation Technology, Inc., 4950 Cranswick, Houston, Texas 77041 | 713-934-0171 | Fax 713-934-9099

## Table of Contents

1. Introduction.....	3
2. Revision Record .....	3
3. WARNING STATEMENT.....	4
4. Storage and Preservation Instructions .....	4
5. Installation .....	5
6. Testing .....	10
7. Maintenance.....	10
8. Terms & Conditions/Warranty .....	13
Appendix .....	14
Appendix A – MP1008 ATI Torque Tightening Guide .....	14

## 1. Introduction

### 1.1. General Note

Automation Technology, Inc. (ATI) was founded in 1995 as a manufacturer of pneumatic and hydraulic linear valve actuators. With products in a wide range of applications such as petro-chemical, pipelines, refineries, pulp and paper, food, drug, municipalities, mining, power plants and ships; ATI has succeeded in becoming The Severe Service Standard in the valve automation industry.

### 1.2. Scope

This manual is intended to assist those who are involved with the installation, operation, and maintenance of ATI Hydraulic Spring Return Retract (SRR) Series Actuators. This manual should be reviewed and thoroughly understood prior to installation, operation, or maintenance on the actuating device. For any questions or clarification please contact the manufacturer.

### 1.3. Type

This IOM Manual is strictly intended for ATI Hydraulic SRR Series Actuators. Failure to read and comply with installation, operation, and maintenance instructions will void the manufacturer's warranty and may result in bodily injury or equipment damage.

### 1.4. Receiving

Proper care and precautions should be taken when unloading and handling the actuator, especially when rigging and lifting. Ensure that the valve is not connected to the actuator. The actuator should only be lifted from the lifting ears located on the upper spring cartridge, as shown in the diagram to the right.

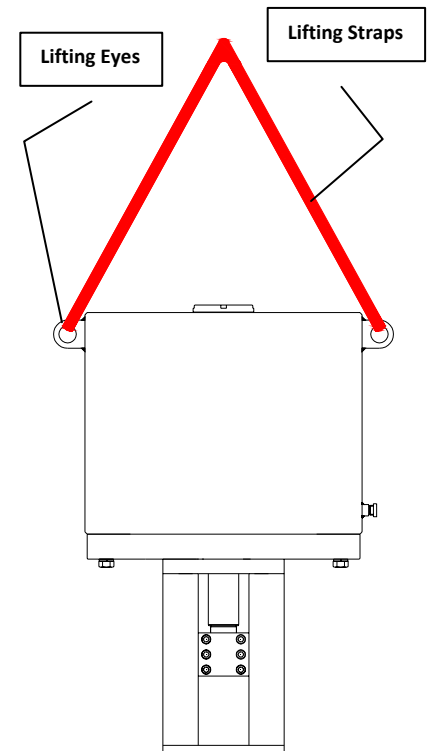

## 2. Revision Record

Rev. #	Issue Date	Description	Engr. Approval eSign & Date	Prepared by eSign & Date
I.R.	01/07/11	Initial Release	S.Michalcik, 1/27/11	Aneil Ali, 01/07/11

### 3. WARNING STATEMENT

BEFORE ATTEMPTING TO INSTALL, OPERATE, SERVICE, OR PERFORM MAINTENANCE ON ANY ATI ACTUATOR, ALL PERSONNEL INVOLVED SHOULD READ AND THOROUGHLY UNDERSTAND THIS MANUAL. THIS MANUAL DOES NOT CLAIM TO ADDRESS ALL SAFETY FACTORS ASSOCIATED WITH ATI ACTUATORS. IT IS THE RESPONSIBILITY OF THE USER TO ENSURE PROPER SAFETY, ALWAYS TAKE NECESSARY PRECAUTIONS AND UTILIZE PROPER PERSONAL PROTECTIVE EQUIPMENT (PPE) WHEN DEALING WITH COMPRESSED AIR, COMPRESSED HYDRAULIC FLUID, PINCH POINTS, AND ELECTRICITY.

VALVE AND ACTUATOR MUST BE RIGGED AND LIFTED SEPARATELY, NEVER AT THE SAME TIME. BEFORE RIGGING, ENSURE THE CRANE/HOIST/RIGGING HARDWARE LIFTING CAPACITY CAN SAFELY ACCOMMODATE THE DESIRED LOAD.

ACTUATORS AND VALVES COME INTO CONTACT WITH CAUSTIC GASES AND FLUIDS IN MANY APPLICATIONS. AS A RESULT, ALL TOXIC OR FLAMMABLE FUMES MUST BE VENTED AND LIQUIDS MOVED TO A SAFE LOCATION. THIS WILL HELP PREVENT PERSONNEL INJURY. THE INSTANTANEOUS RELEASE OF PRESSURE AND VENTING CAN PRODUCE NOISES DUE TO THE DISCHARGE AT SONIC VELOCITY. IT IS THE USER'S RESPONSIBILITY TO UTILIZE APPROPRIATE PROTECTION AGAINST HEARING DAMAGE TO ANY AND ALL NEAR THE ACTUATOR.

SPRING IS UNDER COMPRESSION. DO NOT ATTEMPT TO ADJUST OR DISMANTLE ANY PART OF THE SPRING MECHANISM WITHOUT CONSULTING THE MANUFACTURER, DOING SO MAY RESULT IN SEVERE INJURY OR EVEN DEATH. WHEN OPERATING DEVICE, ENSURE THAT ALL BODY PARTS, TOOLS, AND FOREIGN OBJECTS ARE CLEAR OF THE ACTUATOR'S ADAPTION BRACKET.

WARNING LABELS AND TAGS LOCATED ON THE ACTUATOR ARE MADE OF METAL FOILS THAT VARY IN THICKNESS. BECAUSE THE METAL TAGS HAVE SHARP EDGES, PERSONNEL INSTALLING, HANDLING, OR WORKING AROUND THE TAGS SHOULD PROTECT AGAINST CUTS OR INJURY.

PROPER INSTALLATION OF THE ACTUATOR IS CRITICAL TO PERFORMANCE AND SAFETY. DUE TO THE MANY VARIATIONS OF LINEAR ACTUATORS AND VALVES, THE FOLLOWING ARE GENERAL INSTRUCTIONS. THE TECHNICIAN FOLLOWING THESE INSTRUCTIONS MUST BE COMPETENT, TRAINED, AND HAVE A WORKING KNOWLEDGE OF VALVE ACTUATORS AND VALVES.

FOLLOWING THE ABOVE INSTRUCTIONS WILL HELP IN PREVENTING PERSONAL INJURY, PROPERTY DAMAGE, AND DAMAGE TO THE ACTUATOR.

### 4. Storage and Preservation Instructions

- 4.1. **CAUTION:** Actuators should not be stored in environments harmful to resilient seals. Never use any form of abrasive when cleaning rod surfaces.
- 4.2. Position actuator as it will be stored.
- 4.3. When actuators are stored, piston rods are often exposed to the outside elements for extended periods without cycling. Identify all exposed piston rod areas and pressure ports.
- 4.4. Pressure ports are plugged with plastic plugs during manufacturing/assembly. These plastic plugs should be removed and replaced with steel plugs; a sealant such as pipe dope or Teflon tape should be applied to steel plug threads.
- 4.5. Using a soft cloth dampened with an appropriate oil-based solvent: remove all dirt, dust, grease and contaminants from the exposed piston rod surface.
- 4.6. Inspect the piston rod for surface defects.
- 4.7. Apply a coating of rust preventative solvent to all exposed piston rod surfaces.
- 4.8. Periodically inspect the piston rod surfaces and apply additional rust preventative solvent as needed.
- 4.9. If the actuator will be moved and stored again, repeat the above steps.

For applications where the actuator is not put into immediate service it is recommended that the actuator be stored and preserved properly. Care should be taken to plug all open ports on actuator and controls to keep foreign particles and moisture from entering the actuator. Ideal actuator storage would allow for an indoor environment with a vertical storage position. For extended storage, please contact the manufacturer.

## 5. Installation

### 5.1. HORIZONTAL INSTALLATION

Special care must be taken when installing an actuator to a horizontal service orientation. To avoid cantilever loads on the valve stem and adaption bracket, it is the customer's duty to ensure proper support for the horizontal actuator. Proper support can range anywhere from ground supports to ceiling suspension.

### 5.2. SPLIT COUPLING

#### INSTALLATION PROCEDURE: (FULL CLOSE POSITION)

1. Position the subject valve to the full close position (tight shut off).
2. Remove the hand-wheel and hand-wheel drive assembly. (See Valve Assembly/Disassembly Instructions).
3. Position the Actuator in the full close (fully extended) position. This applies to the DA and SRR models only.
4. Remove the Cap Screws that fix the Actuator to the Adaptation Bracket and install two (2) ¼" shims, 180 degrees apart between the Actuator Lower Head and the Adaptation Bracket and reinstall the Cap Screws.
5. Remove the Coupling Block (ITEM 1) by removing (ITEM 2) cap screws.
6. Install the Adaptation Bracket onto the valve. The hardware may vary depending on the application and type of valve being actuated.
7. Install the Coupling Block (ITEM 1) on to the valve stem and Actuator piston rod (split coupling block) using cap screws (ITEM 2).
8. Install and tighten the (ITEMS 3,4,) fasteners. Fastener types and mounting positions may vary depending on your application.
9. Loosen Cap Screws connecting the Actuator Lower Head and Bracket, remove the two (2) shims previously installed and tighten Cap Screws.
10. Cycle Actuator fully opened and fully closed and ensure full stroke and smooth operation.

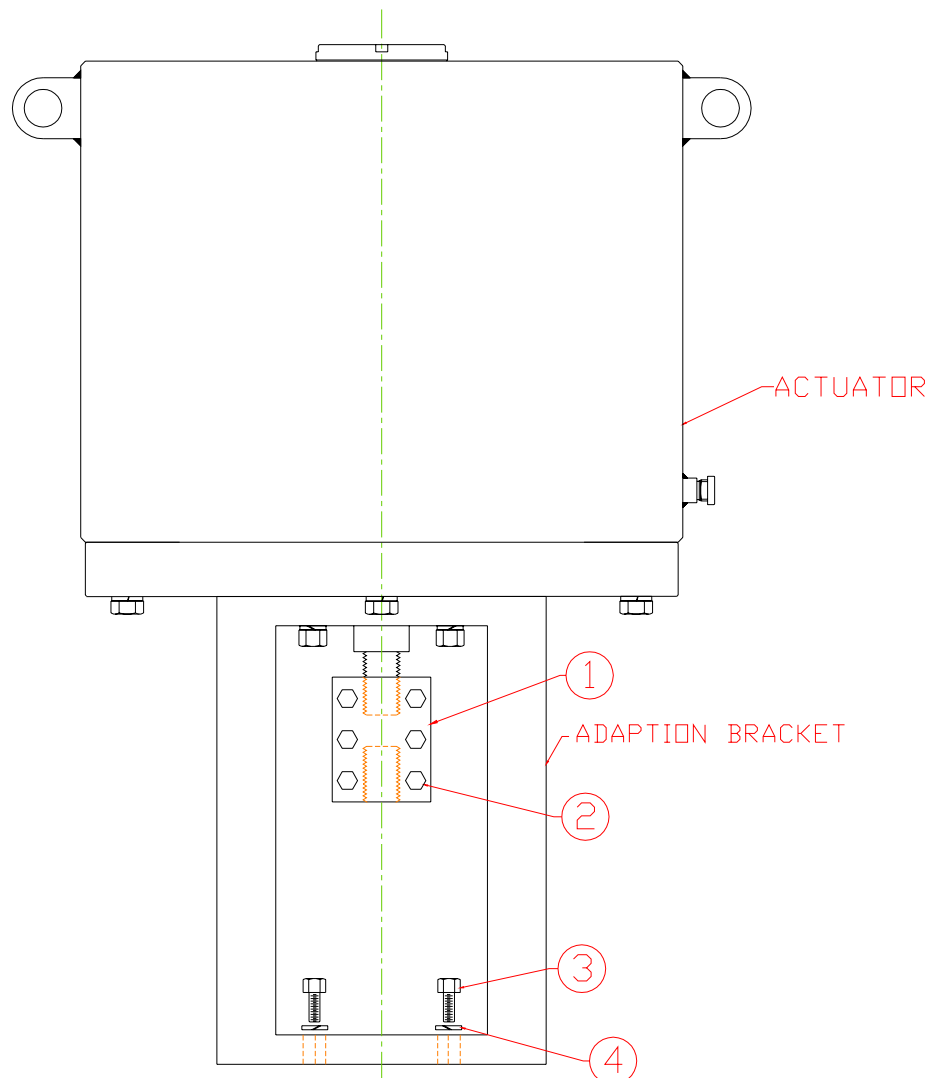

### 5.3. ADJUSTABLE STOPS, SPLIT BLOCK, Ref. Dwg: #8168

#### INSTALLATION PROCEDURE (FULL CLOSED POSITION)

1. Position the subject valve to the full closed position (TIGHT SHUT OFF).
2. Remove the valve hand wheel and hand wheel drive assembly. (SEE VALVE MANUFACTURERS ASSEMBLY/DISASSEMBLY INSTRUCTIONS).
3. Position the actuator in the full closed position (Piston rod (Item 1) fully extended).
4. If applicable, remove the final adaptation assembly (This assembly configuration varies per application) from the bottom of the basic adaptation bracket (Item 2).
5. If applicable, install final adaptation on subject valve.
6. Remove the position indicator guide, screws and lock washers, if Items exist on basic adaptation.
7. Remove the position indicator from the split coupling block (Item 3).
8. Remove split coupling block (Item 3) by removing bolts (Item 4) and lock washers (Item 5).
9. Position the actuator and the basic adaptation to the final adaptation or the valve as per application. Attach with the appropriate fasteners (Items 6 & 7) the recommended torque specs.
10. Install split coupling block (Item 3), by clamping on valve stem and piston rod (Item 1) threads. Coupling block groove must be clamped over split block guide (Item 8).
11. Reinstall bolts (Item 4) and lock washers (Item 5). Tighten to the recommended torque specs.
12. Reinstall position indicator to split coupling block (Item 3).
13. If applicable reinstall position indicator guide, screws and lock washers.
14. Cycle the actuator to check for full open and full close. Adjustments may be necessary.
15. Adjustments may be made by repositioning the stop adjustment bolts (Item 9) in split coupling block (Item 3). Loosen jam nut (Item 10), then reposition the stop adjusting bolts (Item 9), then cycle actuator for full open and full close.
16. Retighten jam nut (Item 10) to split coupling block (Item 3).

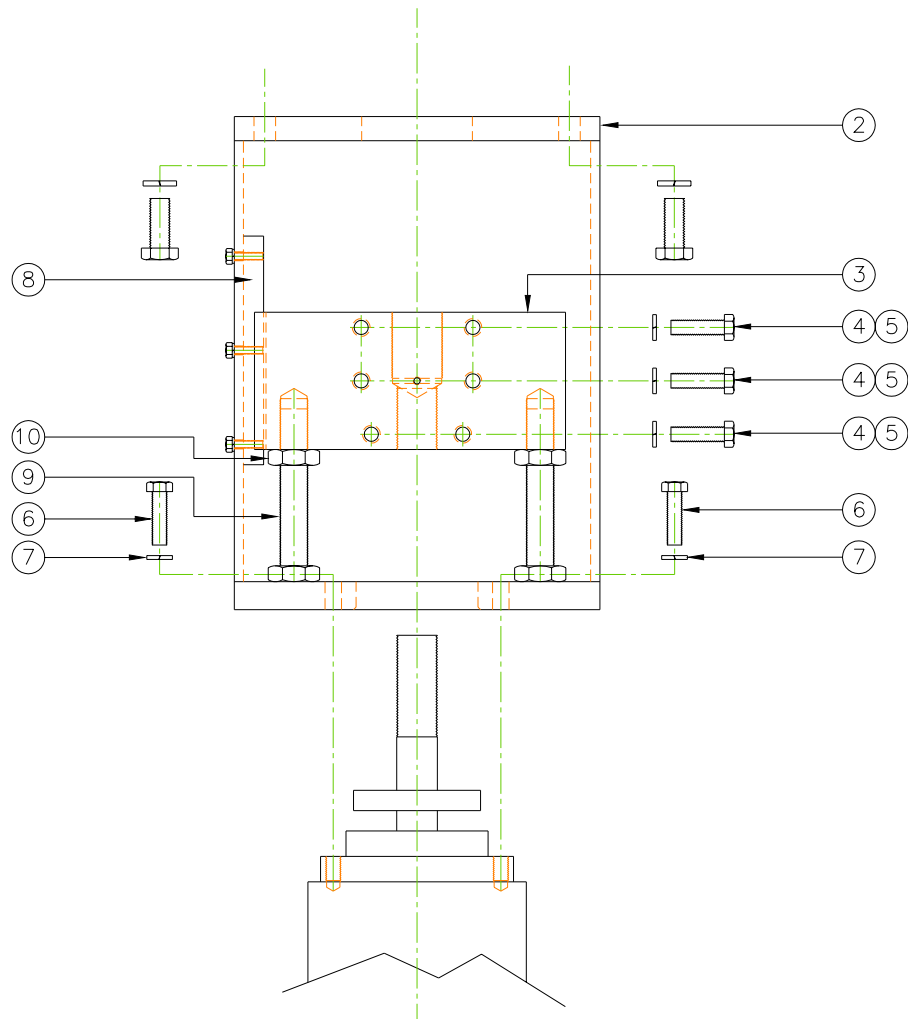

5.4. NO STOPS (SPLIT COUPLING), WITH ANTI-ROTATION PLATE, Ref. Dwg. #16720

INSTALLATION PROCEDURE: (FULL OPEN POSITION)

1. Position the subject valve to the full open position (tight shut off).
2. Remove the hand wheel and hand wheel drive assembly. (See Valve Assembly/Disassembly Instructions).
3. Position the actuator in the full retracted position. The SRR model will be in the retracted position without hydraulic pressure being applied.
4. Remove the coupling block (Item 1) by removing (Item 2) cap screws and lock washers (Item 3).
5. Install the actuator onto the valve. The hardware may vary depending on the application and type of valve being actuated.
6. Install the coupling block (Item 1) on to the valve stem and actuator piston rod. Make sure you have a minimum of one thread diameter of valve stem engaged into coupling block. Install anti-rotation plate (Item 4) thru slot in adaptation bracket and fasten it to coupling block (Item 1) using cap screws (Item 2) and lock washers (Item 3).
7. Cycle actuator fully opened and fully closed. Check for full stroke and smooth operation.

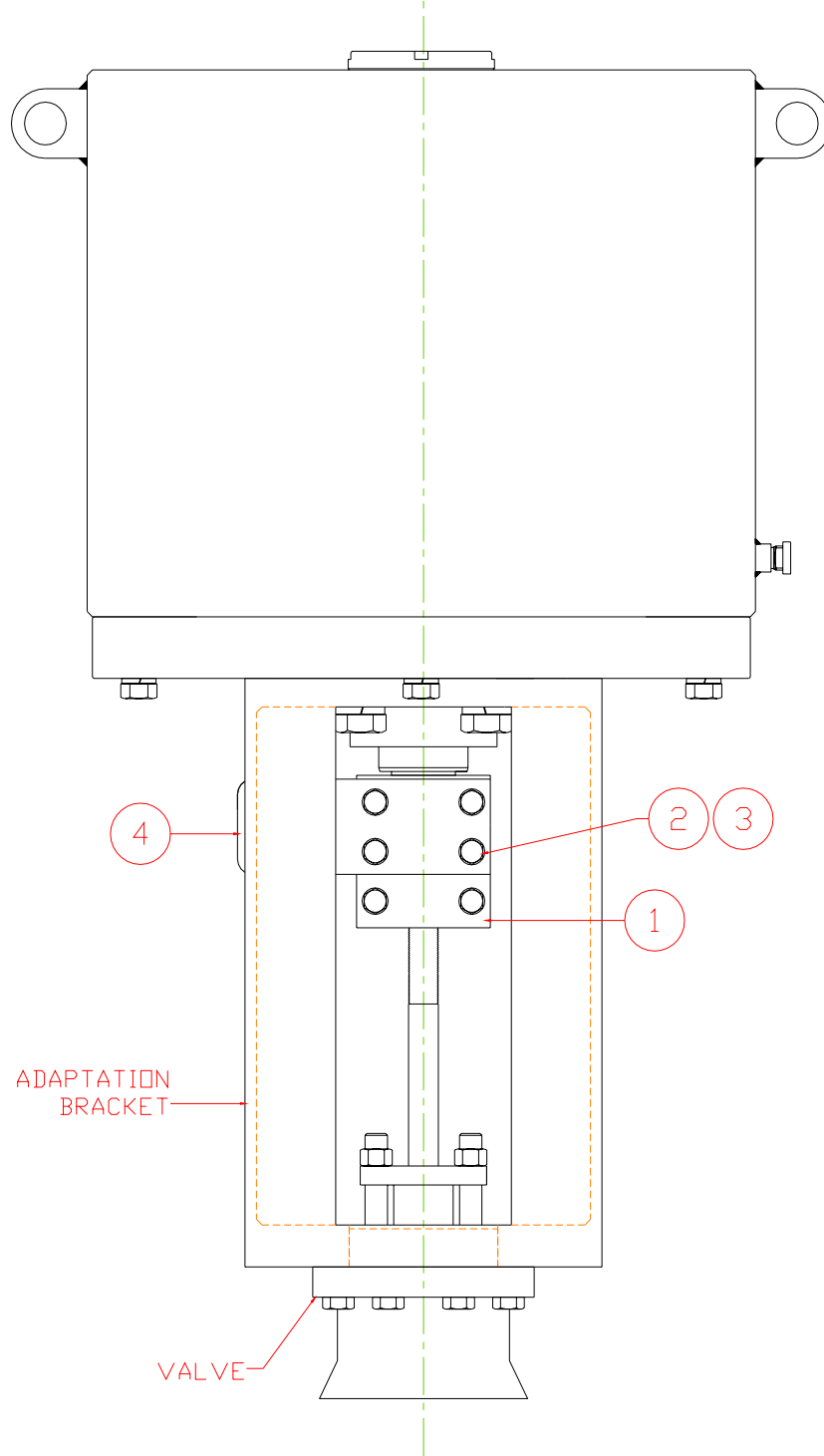

### 5.5. UP STOPS ONLY (SPLIT COUPLING BLOCK), Ref. Dwg. #6828

#### INSTALLATION PROCEDURE: (FULL CLOSE POSITION)

1. Position the subject valve to the full close position (tight shut off).
2. Remove the hand wheel and hand wheel drive assembly. (See Valve Assembly/Disassembly Instructions).
3. Position the Actuator in the full close (fully extended) position.
4. Remove the split coupling block (Item 1) by removing (Item 2) cap screws and lock washers (Item 6).
5. Install the actuator onto the valve, leaving a 1/8" gap between the adaptation bracket and valve. The hardware may vary depending on the application and type of valve being actuated.
6. Install the split coupling block (Item 1) on to the valve stem and actuator piston rod, using cap screws (Item 2) and lock washers (Item 6). Make sure you have at least one full thread diameter of valve stem engaged into split coupling block. Coupling block should be clamping on split block guide (Item 3).
7. Install and tighten the fasteners required for holding the valve to the actuator. Fastener types and mounting positions may vary depending on your application. Tighten fasteners to torque specifications on torque chart provided.
8. Cycle Actuator fully opened and fully closed and ensure full stroke and smooth operation.
9. Adjust stop bolts (Item 4) for valve stroke and tighten jam nuts (Item 5) down on coupling block (Item 1) to torque specifications on torque chart.

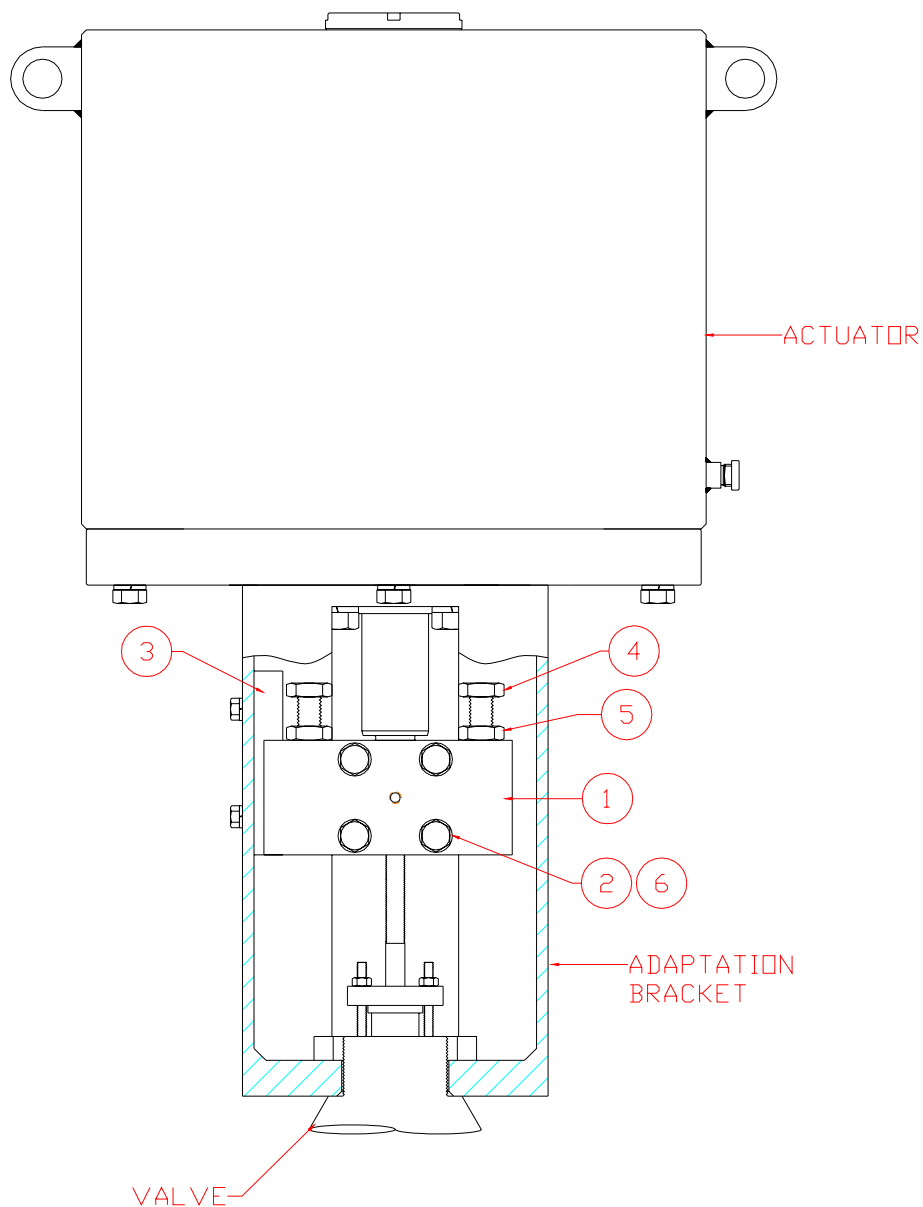

5.7. "HDH" SERIES LINEAR ACTUATORS, ADJUSTABLE STOPS, Ref. Dwg. #6045

INSTALLATION PROCEDURE: (FULL CLOSED POSITION)

1. Position the subject valve to the full closed position (tight shut off).
2. Remove the valve hand wheel and hand wheel drive assembly. (See valve manufacturer's assembly/disassembly instructions).
3. Position the actuator in the full closed (piston rod (Item 1) fully extended) position.
4. Remove the coupling block assembly (Item 2) by removing the coupling block bushing retaining cap screw and lock washer (Items 3 & 4) from the coupling block.
5. Remove the pin spanner wrench (Item 5) from inside the adaption bracket.
6. Position spanner wrench (Item 5) in holes located in the coupling block bushing (Item 6) and turn counter clockwise until completely out of the coupling block. It is not necessary to remove the piston rod insert (Item 7) or set screw (Item 8).
7. Position the actuator in the full open position.
8. Remove position indicator guide (Item 9) screws (Item 10) and lock washers (Item 11).
9. Remove position indicator (Item 12) and stud (Item 13).
10. Position actuator and adaption bracket to final adaption or valve as per application. Attach with appropriate fasteners to recommended torque specs.
11. Position coupling block assembly over valve stem and thread on clockwise for right hand threads or counter clockwise for left hand threads. Thread down on valve stem until bottom of coupling block assembly is within 1/8" to 1/4" of the bottom of the adaption bracket. It is not necessary to remove threaded insert (Item 15).
12. Align the coupling block assembly to locate the position indicator hole with centerline of the adaption bracket.
13. Position the actuator in the full closed position (piston rod (Item 1) fully extended) position very slowly to install piston rod into the coupling block assembly.
14. Reinstall coupling block bushing (Item 6) with pin spanner wrench (Item 5). NOTE: DO NOT FULLY TIGHTEN UNTIL STEP 16 IS COMPLETED.
15. Reinstall position indicator (Item 12) and stud (Item 13).
16. Reinstall position indicator guide (Item 9) screws (Item 10) and lock washers (Item 11).
17. Tighten coupling block bushing (Item 6) with pin spanner wrench (Item 5), then install coupling block bushing retaining cap screw and lock washer (Items 3 & 4).
18. Cycle actuator and check for full open and full close. Adjustment may be necessary.
19. Adjustment may be made by repositioning the stop adjustment bolts (Item 14).
20. Reinstall pin spanner wrench on inside adaptation bracket.

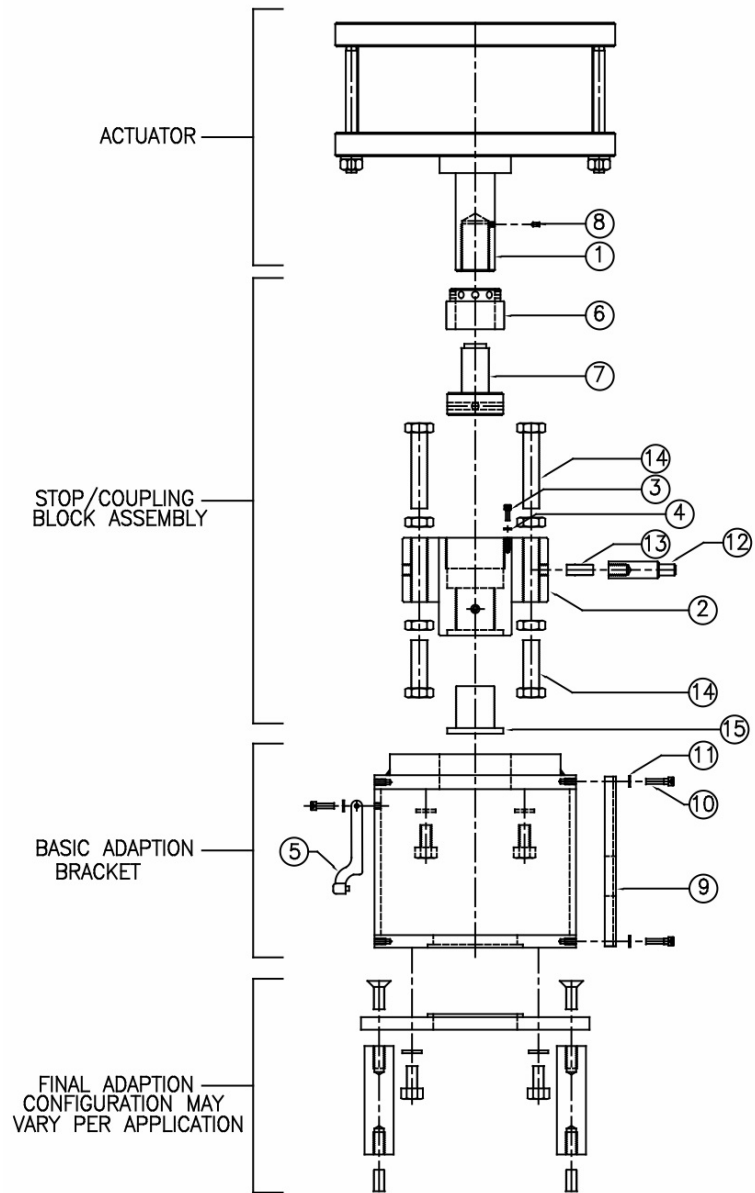

## 6. Testing

- 6.1. Following the installation, standard testing procedures must be followed to ensure proper actuator function.
- 6.2. Connect all necessary hose fittings to the corresponding labeled ports.
- 6.3. Pressurize the lower side of the piston cavity. Ensure that the open/close time and reaction time satisfy specification.
- 6.4. Ensure that the piston rod retracts upon loss of hydraulic pressure or electricity.

## 7. Maintenance

- 7.1. As a result of their robust design and corrosion resistant coatings, ATI Actuators require a minimum amount of maintenance. As with any mechanical application, the service interval is determined by the conditions of use. In an ideal environment the customary service interval is five years. More frequent service may be required in harsh environments.

The Standard contents in the Manufacturer's Maintenance Seal Kit are listed below. If additional seals are required for your actuator, they will be provided with the Manufacturer's Maintenance Seal Kit.

Manufacturer's Maintenance Seal Kit		
ITEM	QTY.	PART DESCRIPTION
A	2	HEAD SEAL O-RINGS, F/HEAD
	2	PARBAKS
B	1	PISTON T-SEAL, 2 BACK UP RINGS
C	2	PISTON WEAR BANDS
D	1	PISTON ROD O-RING
	2	PARBAKS
E	2	BEARING O-RINGS
	2	PARBAKS
F	2	BEARING ROD T-SEAL, 2 BACK UP RINGS
G	2	ROD WIPER RINGS
H	1	O-RING FOR ACCESS CAP

## 7.2. Seal Replacement Instructions

1. Please see the graphic provided below to assist with disassembly and seal replacement.
2. Before rigging, ensure the crane/hoist/rigging hardware lifting capacity can safely accommodate the desired load.
3. Attach rigging hardware and straps to lifting eyes on spring cartridge.
4. With the valve already detached, place actuator in the upright position on a disassembly platform.
5. Loosen/remove the access cap (Item 2).
6. Loosen/remove the hex head cap screw and lock washer (Items 3 and 4).
7. Remove Seal H from the access cap (Item 2).
8. Using proper lifting hardware and equipment, flip actuator so that the lower head (Item 19) is facing up.
9. Loosen/remove socket head cap screws, bearing retaining ring, and bearing (Items 12, 11, and 10).
10. Loosen/remove hex head cap screws and lock washers (Items 20 and 21) from lower head (Item 19).
11. Thread lifting eyes into lower head (Item 19).
12. Attach lifting straps and lift actuator assembly from spring cartridge (Item 1).
13. Using proper lifting hardware and equipment, flip actuator so that the upper head (Item 6) facing up. Place on a flat surface.
14. Loosen male elbow and male connector (Items 17 and 18) on the hydraulic tubing.
15. On the upper head (Item 6): Loosen/remove socket head cap screws, bearing retaining ring, and bearing (Items 12, 11, and 10).
16. In a criss-cross pattern, loosen/remove hex head nuts and lock washers (Items 13 and 14) from upper head (Item 6).
17. Thread lifting eyes in upper head (Item 6).
18. Attach lifting straps and remove upper head (Item 6) from cylinder (Item 7).
19. Thread lifting eye into the hydraulic piston rod (Item 5).
20. Lift piston, hydraulic piston rod, and lower piston rod assembly (Items 9, 5, 15) out of the cylinder (Item 7).
21. Remove tie rods (Item 8) from the lower head (Item 19).
22. Remove piston T-seal and wear bands (Items B and C) from piston (Item 9).
23. Thread locking compound is applied to the piston rod threads by the manufacturer during initial assembly. As a result, disassembly will require heating to loosen the thread locking compound. To remove the piston rod seal (Item D), heat the piston assembly using a torch and unthread piston rod from piston (Item 6).
24. Be careful not to handle the piston rod until it has completely cooled.
25. To ensure all seals are removed/replaced, refer to *Detail 1* and *Detail 2* in the diagram on the following page.
26. Refer to ATI MP1012 Hydraulic SRR Assembly Procedure for reassembly after seal replacement.

BILL OF MATERIALS		
ITEM NO.	QTY.	DESCRIPTION
1	1	SPRING CARTRIDGE ASSEMBLY
2	1	ACCESS CAP
3	1	HHCS, 1 1/2-12UNC X 3.250
4	1	LOCK WASHER, 1 1/2"
5	1	HYD. PISTON ROD
6	1	SR HEAD
7	1	CYLINDER
8	*	TIE BOLT
9	1	PISTON
10	2	BEARING
11	2	BEARING RETAINING RING
12	*	SHCS, 5/16-18UN X 1" LG.
13	*	HHN, 3/4-16UNF
14	*	LOCK WASHER, 3/4"
15	1	LOWER PISTON ROD
16	1	BREATHER VENT
17	1	MALE ELBOW, 3/8T×3/8MNPT
18	1	MALE CONNECTOR, 3/8T×3/8MNPT
19	1	SRR LOWER HEAD
20	*	HHCS, 3/4-10UNC X 3.250
21	*	LOCK WASHER, 3/4"
22	1	SEAL KIT
23	1	MALE ELBOW, 1/2" NPT
24	1	CHECK VALVE, 1/2" NPT

\* Quantity Varies

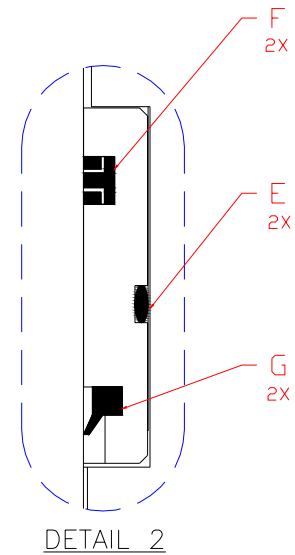
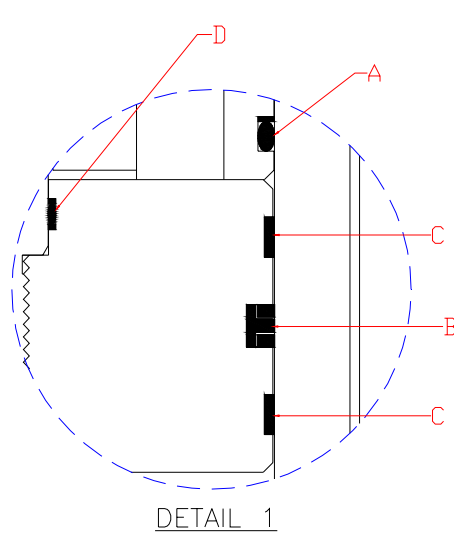
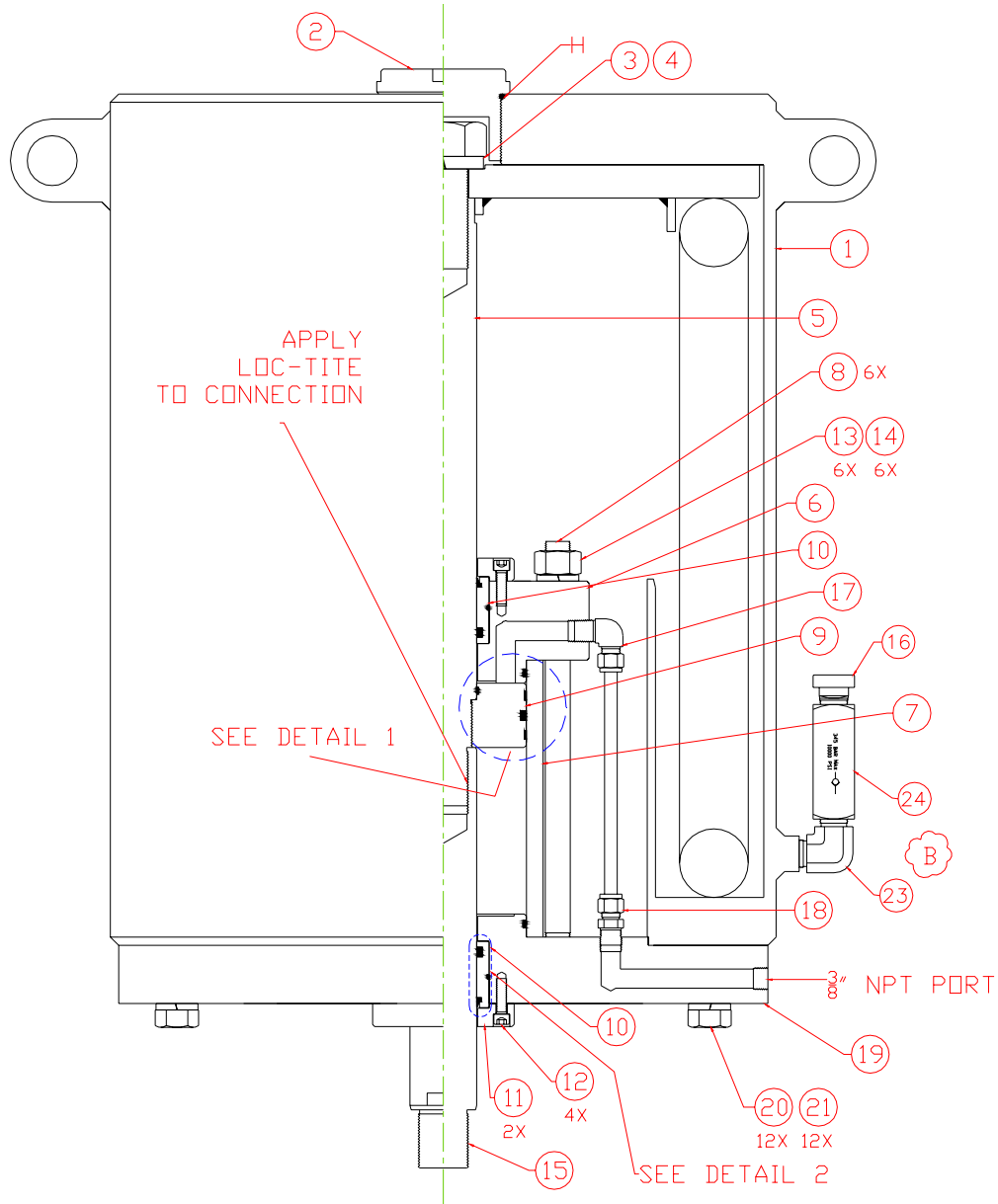

## 8. Terms & Conditions/Warranty

Automation Technology, Inc. (hereinafter "ATI") products are sold under the following terms and conditions:

**A. ACCEPTANCE** – All orders based on "ATI" Quotations shall be subject to acceptance in writing by "ATI". This acceptance is expressly conditional upon assent of the Purchaser to any of our terms, set forth below, which are different or additional to those contained in the Purchase Order. Customer accepts "ATI's" Terms & Conditions of Sale by issuance of a Purchase Order.

**B. PRICES** – "ATI" Quotations are valid for thirty (30) days from date of issuance, unless otherwise stated in writing and are subject to withdrawal or change at any time, prior to acceptance by "ATI". Prices are FOB Factory. Prices are firm for sixty (60) days from date of acceptance of order. If, for any reason, shipment is not made within sixty (60) days, prices in effect at the time of shipment will apply, unless otherwise stated in writing. All Sales Tax, Use Tax or other Excise Tax, which "ATI" is required by law to pay, on or in conjunction with the sale, will be added to the price quoted. "ATI" reserves the right to bill such Tax at the time of material shipment, or any subsequent time thereafter, without forfeiture of collection rights. All orders are subject to federal, state or other governmental regulation that is in effect, or later becomes effective. Typographical and clerical errors in quotations or orders are subject to correction by "ATI". Prices do not include installation unless so stated in the Quotation. Prices quoted include one (1) copy of any applicable manuals; additional printed material requested by the Purchaser is subject to additional cost, quoted at the time of request by Purchaser.

**C. PAYMENT** – "ATI" requires payment to be received within thirty (30) days from date of invoice. In the case of orders to be delivered overseas, "ATI" reserves the right to require, before commencement of work, assurance of payment in the form of a letter of credit or an equivalent, which is acceptable to "ATI". There will be a 1.5 percent interest charge per month on any account not paid within 30 days from date of invoice. Orders will be invoiced by "ATI" when shipped. "ATI" reserves the right to invoice the Purchaser for any, or all material ready for shipment, which has been held at the request of Purchaser, shipment delayed for instrumentation or other components not received on time or they are defective, or delay for other reasons beyond "ATI's" control.

**D. DELIVERY** – Products are sold FOB Factory. Risk of loss is the responsibility of Purchaser once the shipment is delivered to the transportation carrier.

**E. SHIPPING** – All promised shipping dates are estimated and the date represents the date of shipment, rather than delivery at destination. "ATI's" best effort is used to ship orders by the promised due date, but there is no guarantee to do so. Scheduled shipping dates commence with date of: 1) Acceptance of Purchase Order, 2) Receipt of valve dimensional information, if applicable, 3) Receipt of components required for completion of order, if applicable, or 4) Receipt at "ATI" of drawings, approved by Purchaser, whichever is the latest. Products ordered on an "in stock" basis are subject to prior sale. Purchaser is responsible for payment of shipping costs to deliver the order to the specified destination. In cases where a collect shipment cannot be made, "ATI" reserves the right to bill Purchaser at a later date for shipping charges not known at time of shipment. Charges for export packing, when applicable, will be billed to the Purchaser.

**F. DESIGN** – Due to continuous product development, "ATI" reserves the right to modify design, materials or specifications without prior notice.

**G. CANCELLATION** – Orders accepted by "ATI" are not subject to cancellation except with the written consent of "ATI" and upon terms which will indemnify "ATI" against loss or damage occasioned by such cancellation. After consent as noted, cancellation of the order is subject to cancellation charges for work begun pursuant to the order.

**H. INSPECTION** – Final inspection and acceptance of products must be made at the "ATI" location and shall be conclusive except for latent defects. Purchasers' representative may inspect product during normal business hours as to not interfere with Factory operations.

**I. WARRANTY** – All products manufactured by "ATI" are warranted against defects of material or workmanship for a period of two (2) years after date of shipment to Purchaser, providing products were used within the service for which they were manufactured. This warranty is limited to replacement, without charge, of parts found by "ATI" to be defective in material or workmanship and does not cover labor or other loss or damage occasioned by such defect. This warranty does not cover deterioration by corrosion or any cause of failure other than defects in material or workmanship. Purchaser is expected to determine the suitability of "ATI" products for their particular purposes. "ATI" shall not be liable for any indirect or consequential damages, whether or not "ATI" is negligent, nor shall any recovery of any kind against "ATI" be greater in amount than the purchase price of the specific product sold and causing the alleged loss, damage or injury. Any alleged loss, damage or injury cause of action must commence within one (1) year of alleged loss, damage or injury. THIS WARRANTY SUPERSEDES AND IS IN LIEU OF ALL WARRANTIES OF MERCHANTABILITY AND FITNESS AND ANY OTHER WARRANTY.

**J. RETURNS** – No product may be returned for credit or adjustment without written permission and tagging instruction from "ATI". Upon receipt of approved returns, any handling/restocking charges and/or cost to recondition for resale, will be charged to Purchaser.

Appendix

Appendix A – MP1008 ATI Torque Tightening Guide

STAT-O SEALS OR THREAD SEALS							
COARSE THREADS				FINE THREADS			
BOLT DIA.	CLAMP LOAD LBS.	PLAIN (FT-LBS)	PLATED (FT-LBS)	BOLT DIA.	CLAMP LOAD LBS.	PLAIN (FT-LBS)	PLATED (FT-LBS)
1/4-20	2,850	7	5	1/4-28	3,263	8	6
5/16-18	4,725	13	10	5/16-24	5,113	14	11
3/8-16	6,975	23	18	3/8-24	7,875	25	20
7/16-14	9,600	36	27	7/16-20	10,650	38	29
1/2-13	12,750	54	42	1/2-20	14,400	57	46
9/16-12	16,350	77	60	9/16-18	18,300	63	67
5/8-11	20,325	108	82	5/8-18	23,025	113	92
3/4-10	30,075	189	145	3/4-16	33,600	209	160
7/8-9	41,550	305	231	7/8-14	45,825	335	251
1-8	54,525	456	342	1-12	59,700	498	355
1-1/8-7	68,700	647	487	1-14	61,125	510	383
1-1/4-7	87,225	912	683	1-1/8-12	77,025	724	542
1-3/8-6	103,950	1197	896	1-1/4-12	96,600	1008	755
1-1/2-6	126,450	1585	1187	1-3/8-12	118,350	1357	1025
				1-1/2-12	142,275	1779	1335

ATI TIGHTENING TORQUE GUIDE FOR TIE RODS (100K STRESS PROOF)			
COARSE THREADS		FINE THREADS	
BOLT DIA.	TORQUE FT-LBS AT 100,000 PSI	BOLT DIA.	TORQUE FT-LBS AT 100,000 PSI
1/4-20	6	1/4-28	8
5/16-18	11	5/16-24	13
3/8-16	19	3/8-24	21
7/16-14	29	7/16-20	32
1/2-13	44	1/2-20	47
9/16-12	62	9/16-18	65
5/8-11	85	5/8-18	88
3/4-10	146	3/4-16	152
7/8-9	231	7/8-14	241
1-8	328	1-14	347
1-1/8-7	488	1-1/8-12	498
		1 1/4-12	600

ATI TIGHTENING TORQUE GUIDE(SAE GRADE 8 FASTENERS)							
COARSE THREADS				FINE THREADS			
BOLT DIA.	CLAMP LOAD LBS.	PLAIN (FT-LBS)	PLATED (FT-LBS)	BOLT DIA.	CLAMP LOAD LBS.	PLAIN (FT-LBS)	PLATED (FT-LBS)
1/4-20	2,850	12	9	1/4-28	3,263	14	10
5/16-18	4,725	25	18	5/16-24	5,113	27	20
3/8-16	6,975	44	33	3/8-24	7,875	49	37
7/16-14	9,600	70	52	7/16-20	10,650	78	58
1/2-13	12,750	106	80	1/2-20	14,400	120	90
9/16-12	16,350	153	115	9/16-18	18,300	172	129
5/8-11	20,325	212	159	5/8-18	23,025	240	180
3/4-10	30,075	376	282	3/4-16	33,600	420	315
7/8-9	41,550	606	454	7/8/2014	45,825	668	501
1-8	54,525	909	682	1-12	59,700	995	746
1-1/8-7	68,700	1288	966	1-14	61,125	1019	764
1-1/4-7	87,225	1817	1363	1-1/8-12	77,025	1444	1083
1-3/8-6	103,950	2382	1787	1-1/4-12	96,600	2012	1509
1-1/2-6	126,450	3163	2371	1-3/8-12	118,350	2712	2034
				1-1/2-12	142,275	3557	2668