



THE SEVERE-SERVICE STANDARD IN VALVE AUTOMATION



LINEAR HYDRAULIC ACTUATORS



LINEAR PNEUMATIC ACTUATOR



# ATI LINEAR PNEUMATIC ACTUATORS

## ATI SUPERIOR PNEUMATIC AUTOMATION SOLUTIONS

Our L & HDL series are piston operated valve actuators that use air pressure or natural gas to produce the force required to open, close and control rising stem valves.

Max. working pressure up to 150 psi. Max. thrust available 216,676 lbs.



*Unit after unit, time after time, ATI actuators offer exceptional dependability.*

Piston actuators allow for a high thrust to weight ratio because they can operate at higher supply pressures.

The all steel construction can withstand severe service environments.



*A 42" bore size actuator capable of generating over 200,000 lbs. of force.*

### Performance Highlights

Our L series actuator is perfect for control valves. With smooth operation from speeds as slow as .012 inches per second to speeds as fast as 12 inches in less than a second.

The adaptable nature of our design allows you to automate valves in place without shutting the plant down.



*HDL Series Pneumatic Double Acting Actuator on a Thru Conduit Valve.*

Our piston actuators are constructed to withstand high temperatures and vibrations.

Actuators are ASME III approved for nuclear regulatory quality specifications.



*An entire fleet of Linear Pneumatic Actuators set for a plant turnaround in Brazil.*

**With thousands of units worldwide, ATI has built a strong industry standing.**

### STANDARD SPECIFICATIONS

<b>PISTON DIAMETER</b>	4" THRU 44"
<b>STROKE</b>	1" THRU 50"
<b>MAXIMUM WORKING PRESSURE</b>	150 PSI
<b>STATIC TEST PRESSURE</b>	225 PSI
<b>THRUST</b>	478 lbs. TO 216,676 lbs.
<b>TEMPERATURE RANGE</b>	
STANDARD	-40°F to 200°F
LOW TEMPERATURE	-65°F to 200°F
HIGH TEMPERATURE	-20°F to 400°F

Larger bore sizes, longer strokes and higher pressure are available.

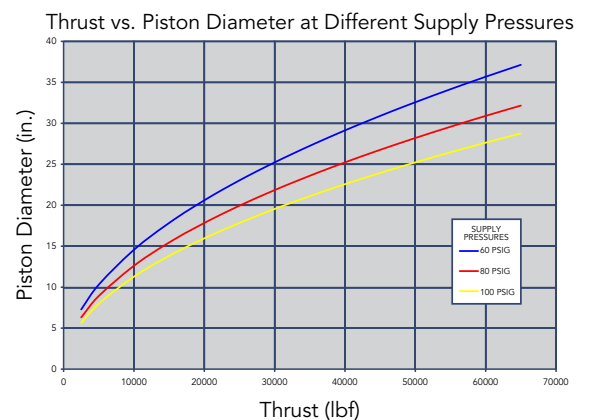

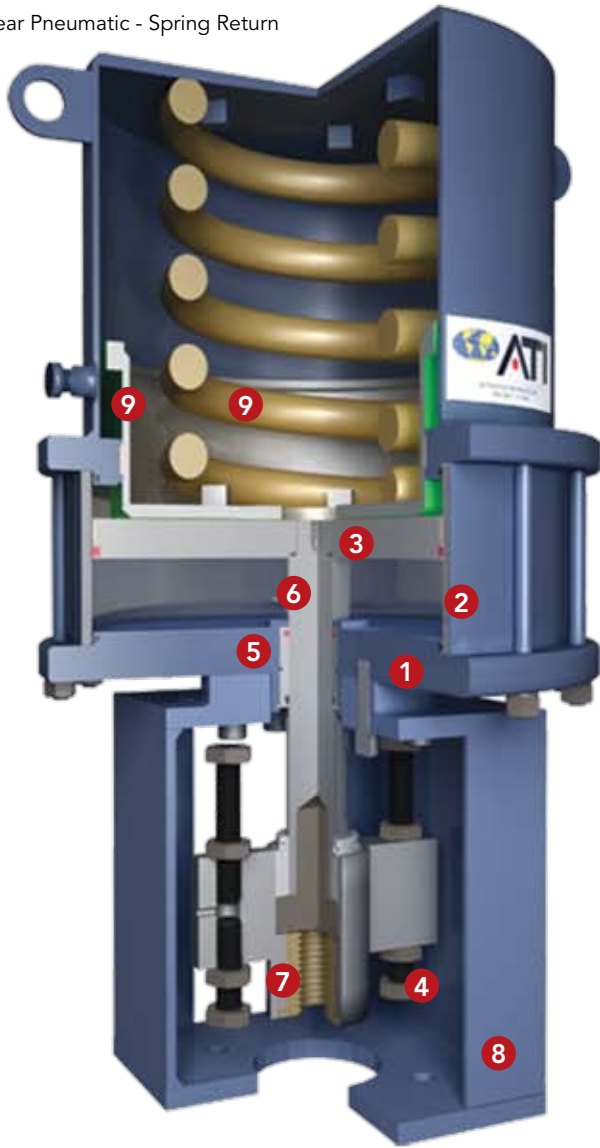

## ATI PRODUCT FEATURES

- 1 Cylinder Heads (Upper and Lower)**  
Precision machined steel cylinder heads provide a true parallel surface for alignment of the cylinder and piston rod bearing.
- 2 Cylinder**  
High strength steel cylinder is honed to a 16RMS finished and hard chrome plated or xylan® coated for enhanced performance and corrosion protection.
- 3 Piston**  
Precision machined steel piston incorporates a anti-friction wear ring and bidirectional quad seal for long trouble free service.
- 4 Travel Stops**  
Externally adjustable travel stops are sized to withstand the full output thrust of the actuator and do not intrude into the pressurized power cylinder.
- 5 Piston Rod Bearing**  
Heavy duty, extra long piston rod bearing is externally removable for ease of service.

- 6 Piston Rod**  
The piston rod is made from 100,000 psi minimum yield high strength alloy steel, ground to a 8 RMS finish and hard chrome plated.
- 7 Coupling Block**  
Unique piston rod to valve stem coupling block allows easy installation and removal of the actuator. A split coupling is used for control valve applications.
- 8 Adaption Bracket**  
One piece open adapter allows for access to travel stops, limit switch adjustment, valve packing adjustment, and actuator removal.
- 9 Spring & Spring Cartridge**  
Springs are pre-compressed and welded into a sealed spring cartridge at the factory for safe, maintenance-free service. Spring rates can be designed for maximum stiffness.

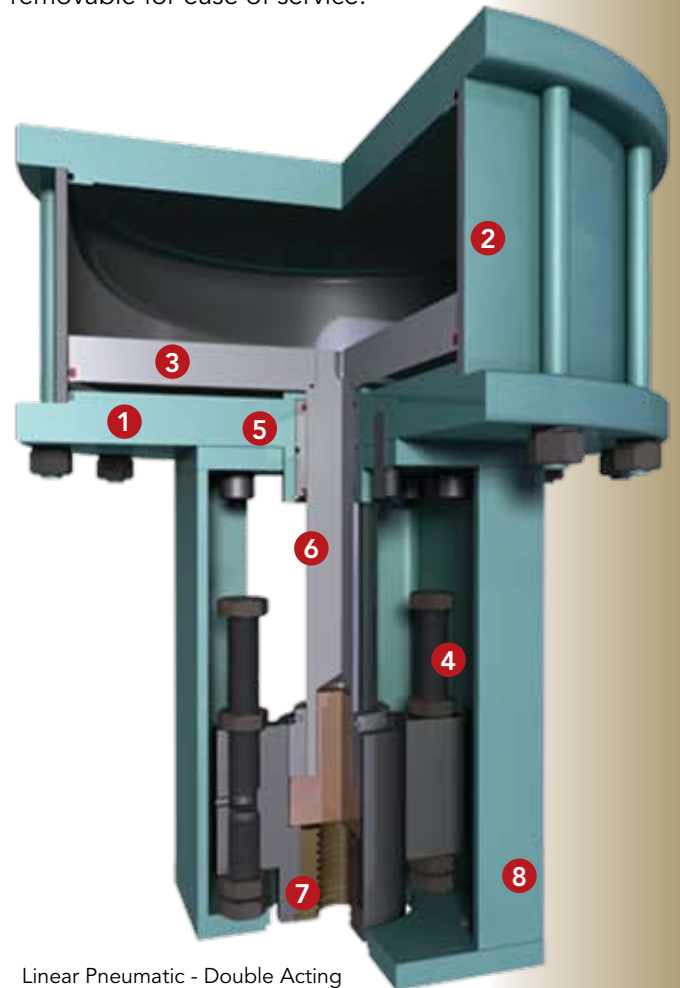

Linear Pneumatic - Double Acting

# ATI LINEAR HYDRAULIC ACTUATORS

## ATI SUPERIOR HYDRAULIC AUTOMATION SOLUTIONS

### Think Thrust!

Our H & HDH series are piston operated valve actuators that use hydraulic pressure or high pressure gas to provide the force required to open, close and control rising stem valves.



*ATI adapts its systems to yours, even helping older plants meet today's demands.*

Built for the rigors of industrial applications, these actuators are designed to take maximum abuse without affecting performance or dependability.



*Hydraulic spring return control valve actuators with explosion-proof ATI positioning systems are ready for shipment.*

### Performance Highlights

- Our H series actuator is ideal for control valves especially when it incorporates the ATI hydraulic positioning system.
- Our HDH series actuator has been effectively used for on/off applications



*Two orange actuators ready for a plant turnaround in Brazil.*

such as steam blow applications that require very fast opening speeds.

- The adaptable nature of our design allows you to automate valves in place without shutting the plant down.



*A high quality hydraulic power system and actuator results in an integrated solution.*

**With thousands of units worldwide, ATI has built a strong industry standing.**

### STANDARD SPECIFICATIONS

<b>PISTON DIAMETER</b>	2" thru 16"
<b>STROKE</b>	1" thru 50"
<b>MAXIMUM WORKING PRESSURE</b>	3000 PSI
<b>STATIC TEST PRESSURE</b>	4500 PSI
<b>THRUST</b>	3000 lbs. to 573,027 lbs.
<b>TEMPERATURE RANGE</b>	
STANDARD	-40°F to 200°F
LOW TEMPERATURE	-65°F to 200°F
HIGH TEMPERATURE	-20°F to 400°F

Larger bore sizes, longer strokes and higher pressure (up to 5000 PSI) are available.

Thrust vs. Piston Diameter at Different Supply Pressures

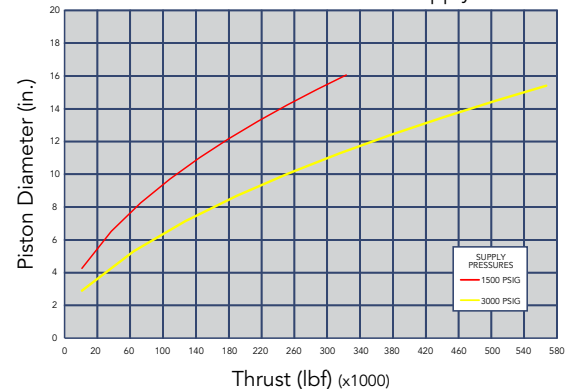

# ATI

## PRODUCT FEATURES

- 1** **Cylinder Heads (Upper and Lower)**  
Precision machined steel cylinder heads provide a true parallel surface for alignment of the cylinder and piston rod bearing.
- 2** **Cylinder**  
High strength steel cylinder is honed to a 16RMS finished.
- 3** **Piston**  
Precision machined steel piston incorporates a anti-friction wear ring and bidirectional quad seal for long trouble free service.
- 4** **Travel Stops**  
Externally adjustable travel stops are sized to withstand the full output thrust of the actuator and do not intrude into the pressurized power cylinder.
- 5** **Piston Rod Bearing**  
Heavy duty, extra long piston rod bearing is externally removable for ease of service.

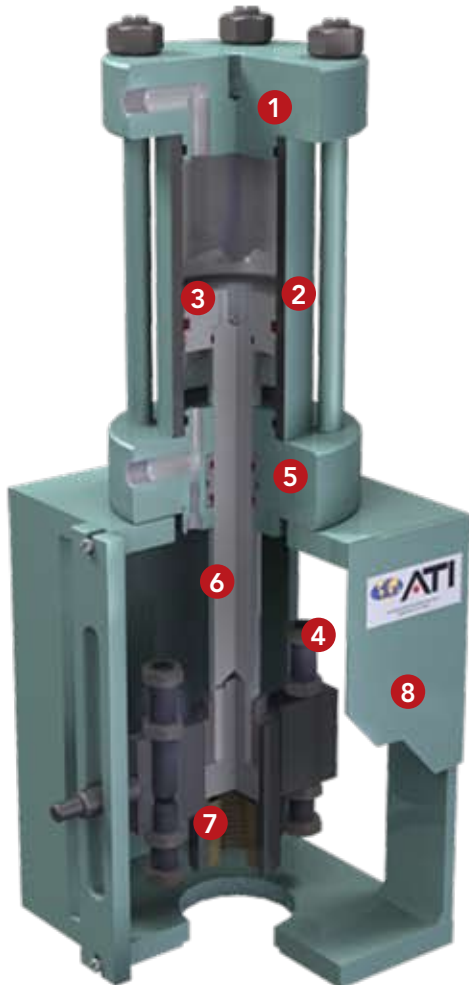

Linear Hydraulic - Double Acting

Linear Hydraulic - Spring Return

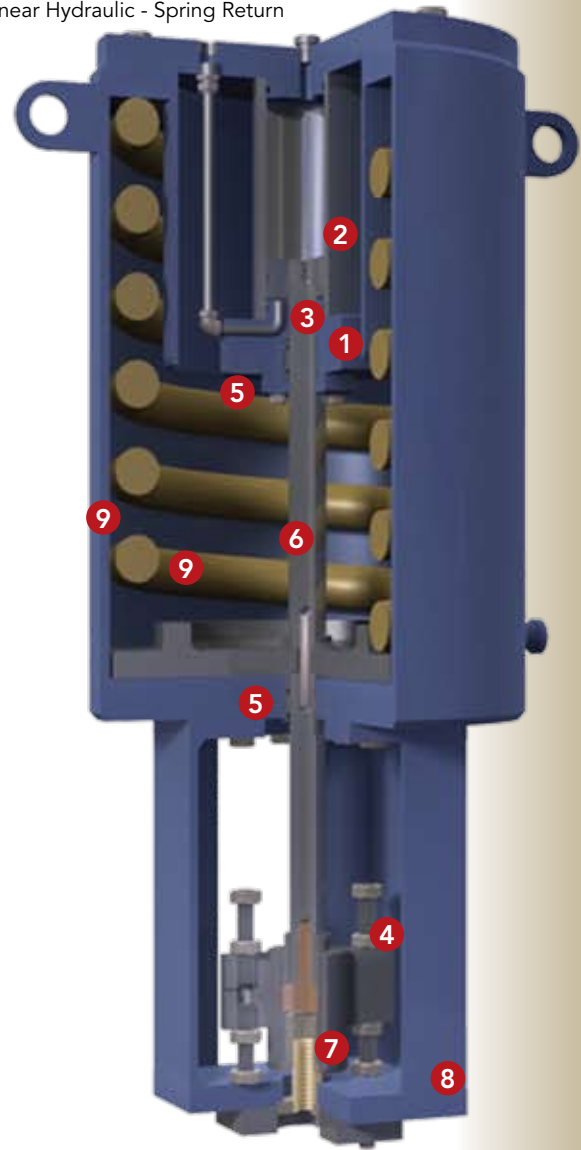

- 6** **Piston Rod**  
The piston rod is made from 100,000 psi minimum yield high strength alloy steel, ground to a 8 RMS finish and hard chrome plated.
- 7** **Coupling Block**  
Unique piston rod to valve stem coupling block allows easy installation and removal of the actuator. A split coupling is used for control valve applications.
- 8** **Adaption Bracket**  
One piece open adapter allows for access to travel stops, limit switch adjustment, valve packing adjustment, and actuator removal.
- 9** **Spring & Spring Cartridge**  
Springs are pre-compressed and welded into a sealed spring cartridge at the factory for safe, maintenance-free service. Spring rates can be designed for maximum stiffness.

# ATI OPTIONS AND ACCESSORIES

## ATI SUPERIOR ALTERNATIVES FOR SUPERIOR PRODUCTS

ATI offers a full line of options to complement your actuator.

### ATI Cushion Actuators

For high speed applications that need a cushioned stroke to protect the valve, this is an ideal application. This actuator is perfectly suited for anti surge valves.

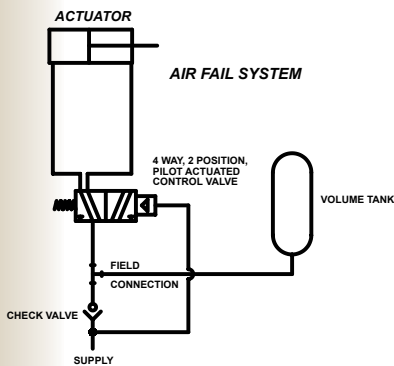
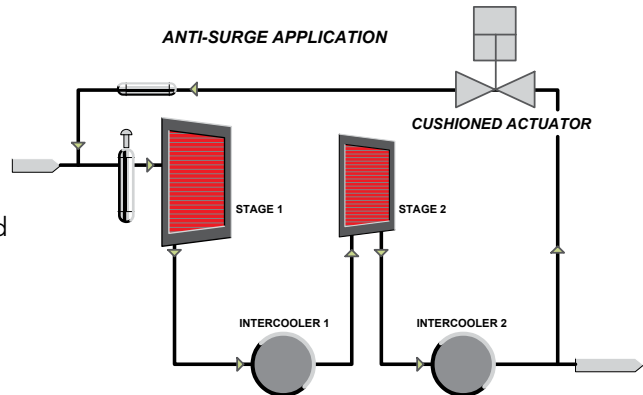

### Air Fail Systems

Air fail systems provide another line of defense against unforeseeable process failures. An air fail system can provide a cost effective alternative to a spring return unit by using a double acting actuator and an air volume tank as shown schematically on the left.

### Stainless Steel Piston Rods

Stainless steel piston rods are necessary for actuators deployed in coastal and offshore environments. The stainless steel helps to deter corrosion making for a higher quality longer lasting actuator.



### Valve Mounting Services

ATI can provide mounting of the actuator to a customer supplied valve. We also provide mounting services for customer supplied controls.

### Field Installation Services

Our expert field engineers will come to your facility and supervise the installation of the actuator onto the valve.

### Lock Out Devices

Lock out devices allow you to lock the actuator in place to ensure a safe work environment during "down the line" repairs.



# ATI MANUAL OVERRIDES

The JS-1 override is a single acting mechanism that will extend the actuator piston rod when operated. This override is intended for infrequent use.

The JS-2 override is capable of extending or retracting the actuator and can be engaged at any position from full open to full closed. Since the entire manual override mechanism is incorporated into the actuator adapter bracket it allows for removal or service of the power cylinder while maintaining complete control of the valve.

The HO-1 is a one way hydraulic override for use on spring return actuators. This override compresses the spring and operates the valve, the spring force is used to move the valve to the failure position.

The HO-2 override is used on double acting actuators and is capable of extending or retracting the actuator. The HO-2 also allows for very precise speed control by regulating the flow of the hydraulic fluid in the system.



JS-2 Manual Override

HO-1 Manual Override



JS-1 Manual Override

# ATI QUALITY EXAMPLES



A hydraulic spring return actuator for a fail open surge control valve located on the Alaskan pipeline requiring very precise positioning while operating at a very high speed.



A double acting pneumatic actuator with stainless braided hose, solenoid, regulator, and limit switch ready for shipment to an oil refinery.



A spring return pneumatic actuator goes on a fail closed gate valve application requiring a linkage-type limit switch and an HO-1 hydraulic manual override for use in a steam line.



A steam blow application is required during the commissioning of a new power plant. An ATI hydraulic actuator and power system (the blue skid in the background) was required to meet the speed requirement of 20 inches in less than a second. Through the course of use the valve wore out and had to be replaced, but the actuator is still in use.

WE TAKE  
YOU  
FROM THIS



TO THIS  
IN ONE  
EASY STEP!

## SAME DAY QUOTE

Visit [www.atiactuators.com](http://www.atiactuators.com) to receive a same day quote from ATI. Consider the following actuator sizing information when placing your order:

- **THE THRUST**  
The amount of force required from the actuator to open and close the valve. Just give us the valve class and type and we can calculate the thrust.
- **THE STROKE**  
The stroke of the valve.
- **THE POWER SOURCE**  
ATI can accommodate any power source; air, hydraulic, electric, solar, etc.
- **THE FAILURE MODE**  
Fail closed, fail open, fail last, etc.

If you are unsure of your needs, a sales representative will be happy to assist you in finding the right solution. Call us today, 979-353-2570 and let's work the problem. ATI also provides valve actuator training at our facility or yours.



Industry Facility  
Design and Fabrication

714 Hwy. 159  
PO Box 310  
Industry, TX 78944

Houston Facility  
Assembly and Sales

4950 Cranswick  
Houston, TX 77041

email: [sales@atiactuators.com](mailto:sales@atiactuators.com)  
web: [www.atiactuators.com](http://www.atiactuators.com)

tel 979.357.2570  
fax 979.357.2571

tel 713.934.0171  
fax 713.934.9099

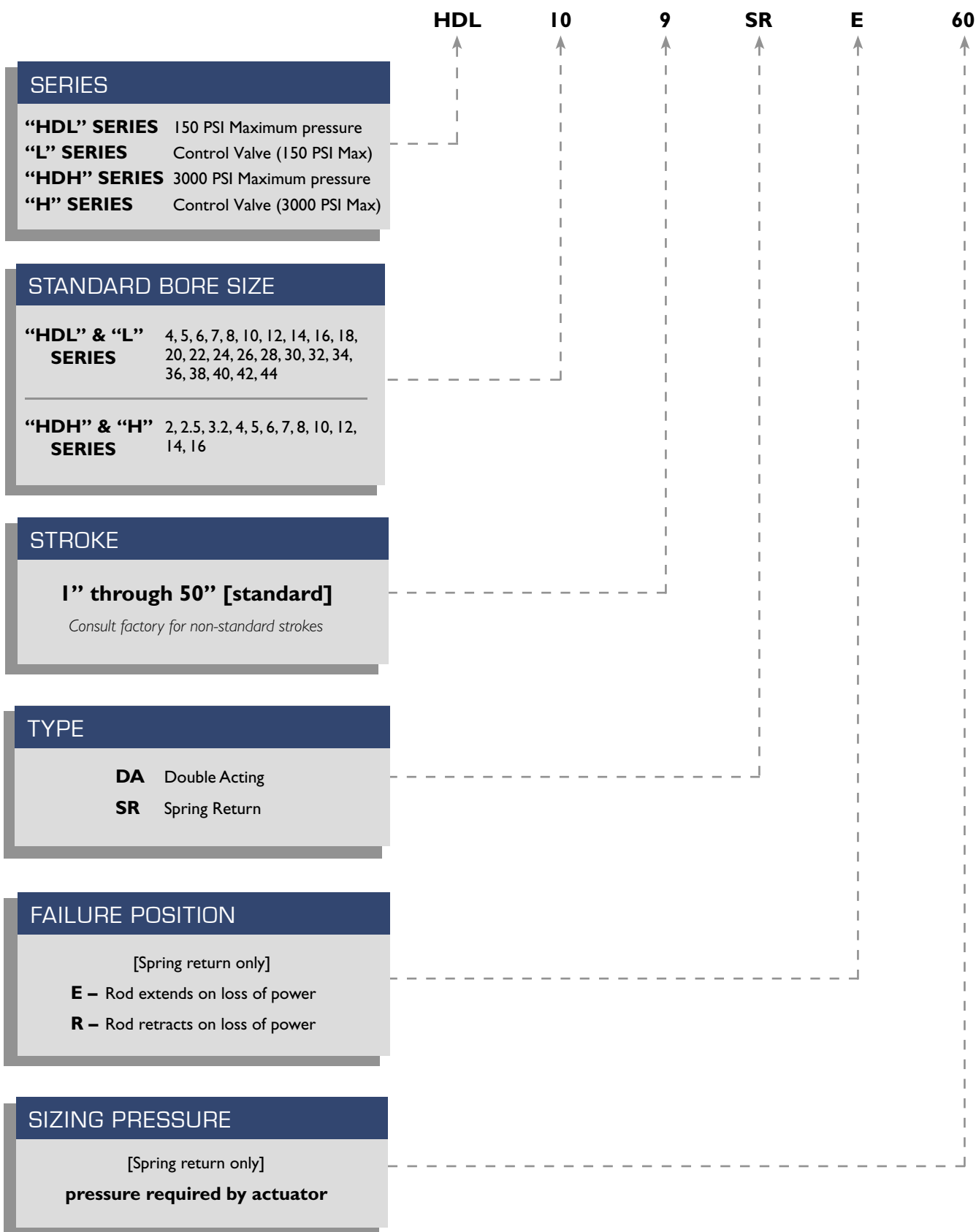

**MANUAL OVERRIDE**

- JS-1** – One way operation only [extends piston rod]
- JS-2** – Two way [extends or retracts piston rod]
- HO-1** – One way hydraulic [extends piston rod]
- HO-2** Two way hydraulic [extends or retracts piston rod]

*NOTE: JS-2, HO-1, and HO-2 overrides are not available on “CEL” Series actuators.*

# Linear Pneumatic Actuator Thrust Chart

Actuator Model Number	40 psi		60 psi		80 psi		100 psi	
	Extend	Retract	Extend	Retract	Extend	Retract	Extend	Retract
HDL4 (*) DA	478	448	716	672	955	895	1194	1119
HDL5 (*) DA	746	716	1119	1074	1492	1433	1865	1791
HDL6 (*) DA	1074	1045	1612	1567	2149	2089	2686	2611
HDL7 (*) DA	1462	1433	2194	2149	2925	2865	3656	3581
HDL8 (*) DA	1910	1819	2865	2728	3820	3637	4775	4547
HDL10 (*) DA	2985	2893	4477	4340	5969	5786	7461	7233
HDL12 (*) DA	4298	4206	6447	6309	8595	8413	10744	10516
HDL14 (*) DA	5850	5663	8774	8495	11699	11326	14624	14158
HDL16 (*) DA	7640	7454	11461	11181	15281	14908	19101	18635
HDL18 (*) DA	9670	9483	14505	14225	19340	18967	24175	23708
HDL20 (*) DA	11938	11669	17907	17504	23876	23339	29845	29174
HDL22 (*) DA	14445	14176	21668	21265	28890	28353	36113	35441
HDL24 (*) DA	17191	16825	25786	25238	34382	33650	42977	42063
HDL26 (*) DA	20175	19810	30263	29715	40351	39620	50438	49524
HDL28 (*) DA	23399	23033	35098	34550	46797	46066	58497	57583
HDL30 (*) DA	26861	26495	40291	39743	53721	52990	67152	66238
HDL32 (*) DA	30561	29957	45842	44936	61123	59914	76404	74893
HDL34 (*) DA	34501	33897	51752	50845	69002	67793	86253	84742
HDL36 (*) DA	38679	38075	58019	57113	77359	76150	96698	95188
HDL38 (*) DA	43096	42492	64645	63738	86193	84984	107741	106230
HDL40 (*) DA	47752	47148	71628	70722	95505	94296	119381	117870
HDL42 (*) DA	52647	52043	78970	78064	105294	104085	131617	130106
HDL44 (*) DA	57780	57176	86670	85764	115561	114352	144451	142940

Consult factory for higher thrust or longer strokes. All models accommodate multiple valve stems.

(\*) Denotes actuator stroke (See explanation of model number) Consult factory for supply pressure under 40 psi and over 100 psi. Maximum Allowable Working Pressure is 150 psi. For thrust at other than charted pressure use the following formula:  
 $(\text{Supply pressure}/100) \times (\text{Thrust at } 100\text{psi}) = \text{Thrust}$

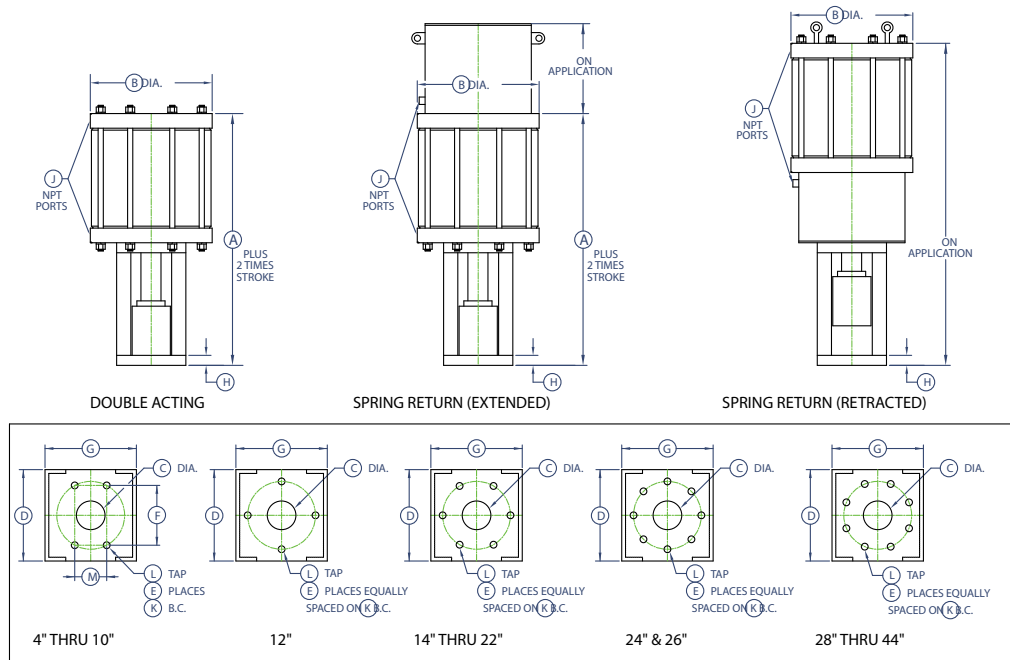

Actuator Model Number	A	B	C	D	E	F	G	H	J	K	L	M	DOUBLE ACTING ONLY		VOL / INCH OF STROKE RETRACTED	VOL / INCH OF STROKE EXTENDED
													BASIC WT ZERO STROKE	WT/ INCH OF STROKE		
HDL4 (*) DA or SR	9.44	6.25	2.50	7.00	4	3.122	7.00	0.44	1/4	3.88	3/8-16	2.298	48	2.74	11.78	12.57
HDL5 (*) DA or SR	9.44	7.25	2.50	7.00	4	3.122	7.00	0.44	1/4	3.88	3/8-16	2.298	55	2.76	18.85	19.64
HDL6 (*) DA or SR	9.44	8.25	2.50	7.00	4	3.122	7.00	0.44	1/4	3.88	3/8-16	2.298	67	3.08	27.49	28.27
HDL7 (*) DA or SR	9.44	9.25	2.50	7.00	4	3.122	7.00	0.44	1/4	3.88	3/8-16	2.298	79	3.45	37.70	38.48
HDL8 (*) DA or SR	12.63	10.13	3.75	8.00	4	5.000	10.00	0.56	3/8	5.59	5/8-11	2.500	146	4.81	47.86	50.27
HDL10 (*) DA or SR	13.25	12.50	3.75	8.00	4	5.000	10.00	0.56	3/8	5.59	5/8-11	2.500	201	5.35	76.13	78.54
HDL12 (*) DA or SR	13.05	15.00	3.75	9.00	4	-	10.50	0.61	1/2	5.83	5/8-11	-	269	6.15	110.69	113.10
HDL14 (*) DA or SR	17.50	17.00	4.75	12.00	6	-	9.38	0.69	1/2	6.50	3/4-10	-	427	9.11	149.03	153.94
HDL16 (*) DA or SR	17.50	19.25	4.75	12.00	6	-	12.00	0.69	1/2	6.50	3/4-10	-	508	10.8	196.15	201.06
HDL18 (*) DA or SR	17.50	21.38	4.75	12.00	6	-	12.00	0.69	1/2	6.50	3/4-10	-	596	11.71	249.56	254.47
HDL20 (*) DA or SR	20.00	23.25	6.00	12.00	6	-	12.00	0.94	3/4	8.50	1"-8	-	818	15.19	307.09	314.16
HDL22 (*) DA or SR	20.00	25.75	6.00	12.00	6	-	12.00	1.19	3/4	8.50	1"-8	-	974	16.46	373.07	380.13
HDL24 (*) DA or SR	21.38	27.75	6.75	18.00	8	-	19.00	1.19	3/4	15.00	1"-8	-	1359	22.25	442.77	452.39
HDL26 (*) DA or SR	21.38	30.25	6.75	18.00	8	-	19.00	1.19	3/4	15.00	1"-8	-	1570	23.69	521.31	530.93
HDL28 (*) DA or SR	21.38	32.25	6.75	18.00	8	-	18.00	1.19	3/4	15.00	1"-8	-	1697	24.58	606.13	615.75
HDL30 (*) DA or SR	21.88	34.50	6.75	18.00	8	-	18.00	1.19	1	15.00	1"-8	-	1986	26.09	697.24	706.86
HDL32 (*) DA or SR	28.50	36.50	8.75	18.00	8	-	18.00	1.19	1	15.00	1"-8	-	2326	28.77	788.35	804.25
HDL34 (*) DA or SR	29.50	38.50	8.75	18.00	8	-	18.00	1.19	1	15.00	1"-8	-	2929	30.55	892.02	907.92
HDL36 (*) DA or SR	29.50	40.50	8.75	18.00	8	-	18.00	1.19	1	15.00	1"-8	-	3144	31.44	1001.97	1017.88
HDL38 (*) DA or SR	29.50	43.00	8.75	18.00	8	-	18.00	1.19	1	15.00	1"-8	-	3484	32.86	1118.21	1134.12
HDL40 (*) DA or SR	30.00	45.13	8.75	18.00	8	-	18.00	1.19	1	15.00	1"-8	-	4005	35.00	1240.74	1256.64
HDL42 (*) DA or SR	30.00	47.13	8.75	18.00	8	-	18.00	1.19	1	15.00	1"-8	-	4319	35.89	1369.54	1385.45
HDL44 (*) DA or SR	31.00	49.13	8.75	18.00	8	-	18.00	1.19	1	15.00	1"-8	-	5151	36.78	1504.63	1520.53

(\*) Denotes actuator stroke

CONSULT FACTORY FOR OVERALL LENGTH AND WEIGHTS FOR SPRING RETURN MODELS VOLUME IS IN CUBIC INCHES, DIMENSIONS ARE IN INCHES, WEIGHTS ARE IN POUNDS (LBS). LIFTING EYES ARE AVAILABLE FOR DOUBLE ACTING MODELS ON REQUEST (4" BORE THRU 16" BORE) 18" THRU 44" BORE LIFTING EYES ARE STANDARD

# Linear Hydraulic Actuator Thrust Chart

Actuator Model Number	500 psi		750 psi		1000 psi		1500 psi	
	Extend	Retract	Extend	Retract	Extend	Retract	Extend	Retract
HDH2 (*) DA	1492	1119	2238	1679	2985	2238	4477	3358
HDH2.5 (*) DA	2332	1959	3497	2938	4663	3917	6995	5876
HDH3.2 (*) DA	3940	3235	5911	4853	7881	6470	11821	9706
HDH4 (*) DA	5969	4827	8954	7240	11938	9653	17907	14480
HDH5 (*) DA	9327	7834	13990	11752	18653	15669	27980	23503
HDH6 (*) DA	13430	11099	20146	16648	26861	22197	40291	33296
HDH7 (*) DA	18280	14923	27420	22384	36560	29845	54841	44768
HDH8 (*) DA	23876	19306	35814	28959	47752	38612	71628	57918
HDH10 (*) DA	37307	29752	55960	44628	74613	59504	111920	89256
HDH12 (*) DA	53721	42436	80582	63654	107443	84872	161164	127308
HDH14 (*) DA	73121	61836	109681	92753	146241	123671	219362	185507
HDH16 (*) DA	95505	84219	143257	126329	191009	168439	286514	252658

Consult factory for higher thrust or longer strokes. All models accommodate multiple valve stems.

(\*) Denotes actuator stroke (See explanation of model number) Consult factory for supply pressure under 500 psi and over 1500 psi. Maximum Allowable Working Pressure is 3000 psi. Larger bore sizes, longer strokes and higher pressure (up to 5000 PSI) are available. For thrust at other than charted pressure use the following formula:  $(\text{Supply pressure} / 1000) \times (\text{Thrust at 1000psi}) = \text{Thrust}$

Example: HDH2.5 (\*) DA with 600 psi supply pressure, extend direction  $(600 / 1000) \times 4663 = 2798$  lbs. Thrust

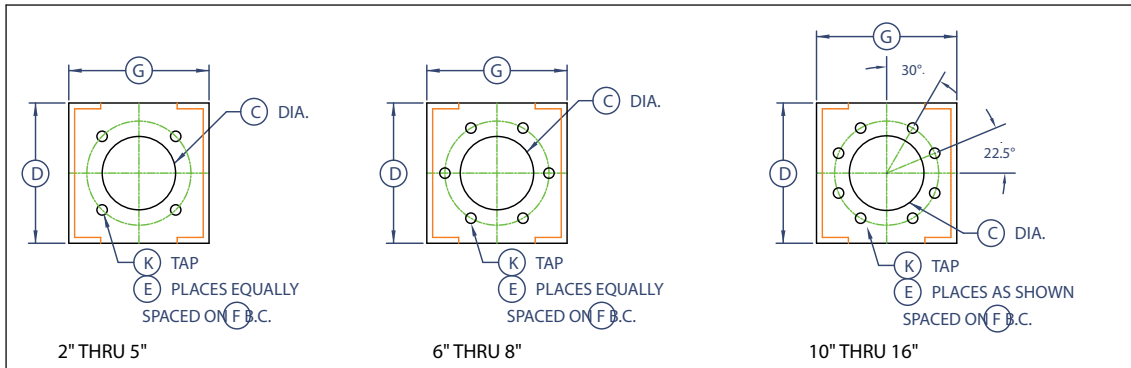
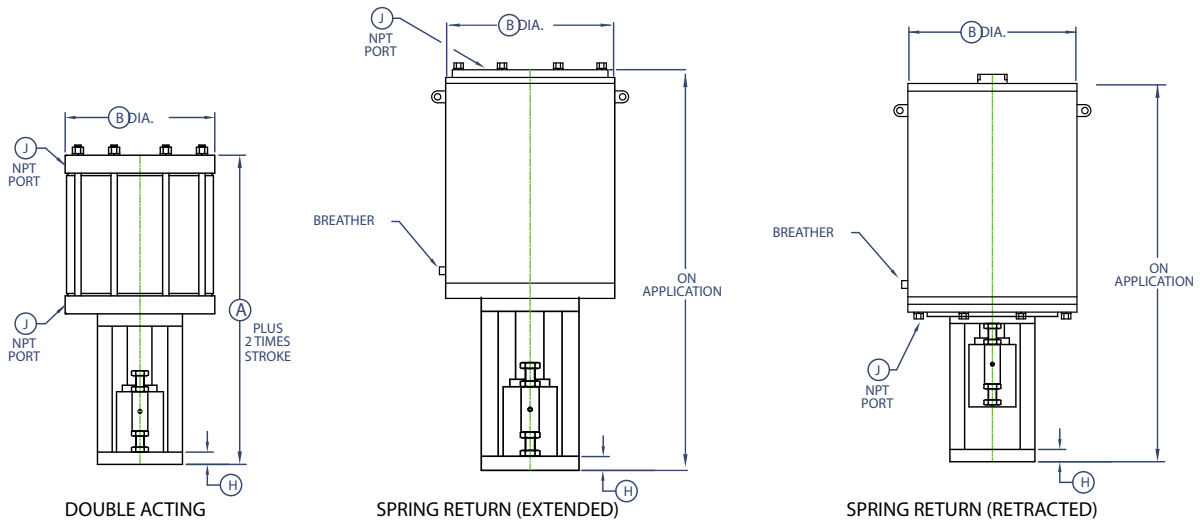

Actuator Model Number	A	B		C	D	E	F	G	H	J	K	DOUBLE ACTING ONLY		VOL / INCH OF STROKE RETRACTED	VOL / INCH OF STROKE EXTENDED
		SR	DA									BASIC WT ZERO STROKE	WT/ INCH OF STROKE		
HDH2 (*) DA or SR	11.56	4.38	10.75	2.50	7.00	4	4.13	7.00	0.56	1/4	7/16-14	44	2.82	2.35	3.14
HDH2.5 (*) DA or SR	11.56	4.88	12.75	2.50	7.00	4	4.13	7.00	0.56	1/4	1/2-13	49	2.93	4.12	4.91
HDH3.2 (*) DA or SR	13.69	6.44	16.00	3.25	8.00	4	5.25	9.00	0.69	3/8	5/8-11	81	4.65	6.81	8.30
HDH4 (*) DA or SR	14.81	7.19	18.00	3.75	10.00	4	6.00	10.00	0.69	3/8	3/4-10	124	7.04	10.16	12.57
HDH5 (*) DA or SR	15.06	8.75	20.00	4.00	12.00	4	7.00	12.00	0.94	3/8	1"-8	201	8.47	16.49	19.64
HDH6 (*) DA or SR	19.94	11.50	24.00	4.75	12.00	6	8.00	12.00	0.94	1/2	1"-8	305	10.00	23.37	28.27
HDH7 (*) DA or SR	24.44	12.00	28.00	6.00	15.00	6	9.00	15.00	1.44	3/4	1"-8	556	14.39	31.42	38.48
HDH8 (*) DA or SR	26.56	13.50	32.00	6.75	18.00	6	10.00	18.00	1.69	3/4	1 1/8-12	827	17.59	40.64	50.27
HDH10 (*) DA or SR	32.31	15.63	O/A	8.75	18.00	8	12.00	18.00	1.94	3/4	1 1/8-12	1254	22.57	62.64	78.54
HDH12 (*) DA or SR	37.75	18.38	O/A	9.75	18.00	8	13.00	18.00	1.69	3/4	1 1/4-12	1756	31.67	97.19	113.10
HDH14 (*) DA or SR	40.69	20.38	O/A	9.75	18.00	8	14.00	19.00	1.94	3/4	1 1/2-12	2262	42.08	130.18	153.94
HDH16 (*) DA or SR	41.63	23.88	O/A	9.75	18.00	8	14.00	19.00	1.94	3/4	1 1/2-12	2908	44.23	177.3	201.06

(\*) Denotes actuator stroke (O/A) Denotes On Application

CONSULT FACTORY FOR OVERALL LENGTH AND WEIGHTS FOR SPRING RETURN MODELS VOLUME IS IN CUBIC INCHES, DIMENSIONS ARE IN INCHES, WEIGHTS ARE IN POUNDS (LBS). LIFTING EYES ARE AVAILABLE FOR DOUBLE ACTING MODELS 10 THRU 16. LIFTING EYES ARE STANDARD FOR SPRING RETURN MODELS