

INSTALLATION, OPERATION & MAINTENANCE MANUAL

Hydraulic Spring Return Retract (SRR) Linear Actuators

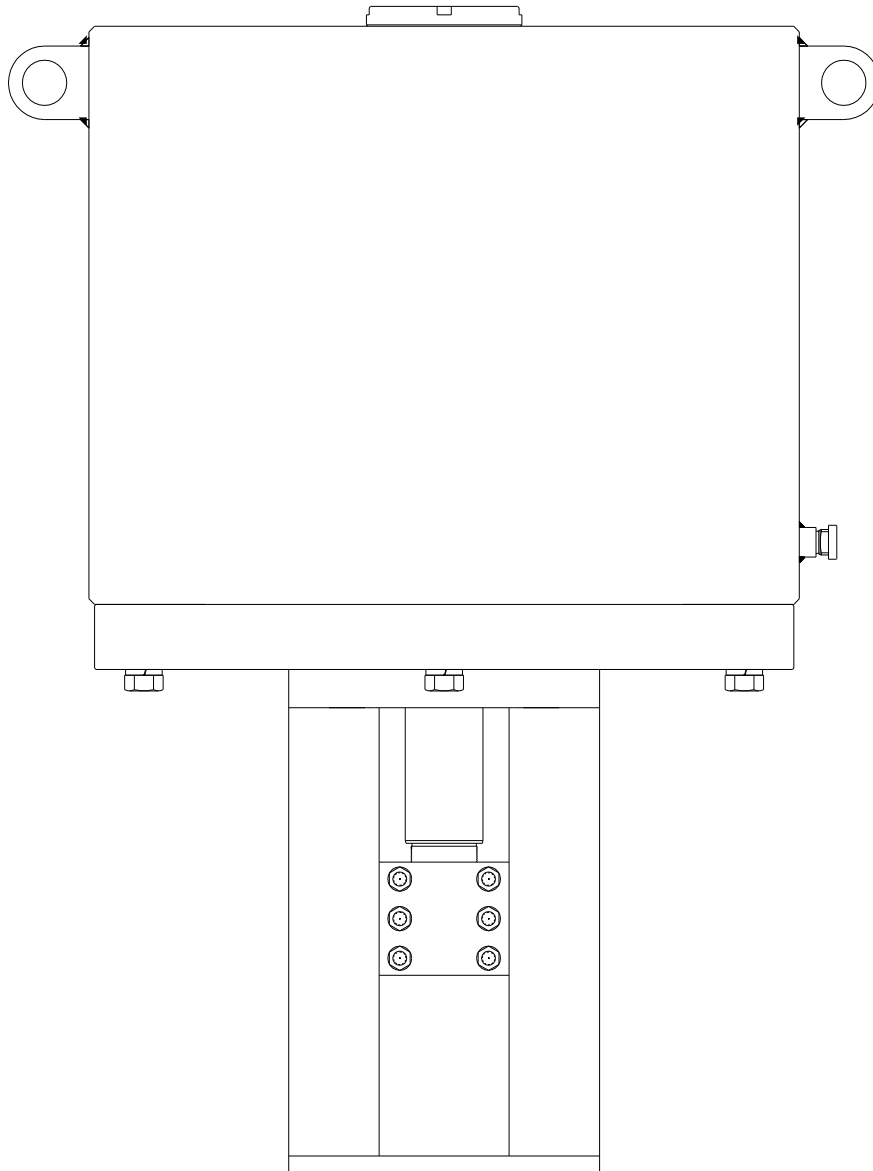

The Severe Service Standard in Valve Automation

Table of Contents

1. Introduction.....	3
2. Revision Record.....	3
3. WARNING STATEMENT.....	4
4. Storage and Preservation Instructions.....	4
5. Installation.....	5
6. Testing.....	10
7. Maintenance.....	10
8. Terms & Conditions/Warranty.....	13
Appendix.....	15
Appendix A – MP1008 ATI Torque Tightening Guide.....	15

1. Introduction

1.1. General Note

Automation Technology, Inc. (ATI) was founded in 1995 as a manufacturer of pneumatic and hydraulic linear valve actuators. With products in a wide range of applications such as petro-chemical, pipelines, refineries, pulp and paper, food, drug, municipalities, mining, power plants and ships; ATI has succeeded in becoming The Severe Service Standard in the valve automation industry.

1.2. Scope

This manual is intended to assist those who are involved with the installation, operation, and maintenance of ATI Hydraulic Spring Return Retract (SRR) Series Actuators. This manual should be reviewed and thoroughly understood prior to installation, operation, or maintenance on the actuating device. For any questions or clarification please contact the manufacturer.

1.3. Type

This IOM Manual is strictly intended for ATI Hydraulic SRR Series Actuators. Failure to read and comply with installation, operation, and maintenance instructions will void the manufacturer's warranty and may result in bodily injury or equipment damage.

1.4. Receiving

Proper care and precautions should be taken when unloading and handling the actuator, especially when rigging and lifting. Ensure that the valve is not connected to the actuator. The actuator should only be lifted from the lifting ears located on the upper spring cartridge, as shown in the diagram to the right.

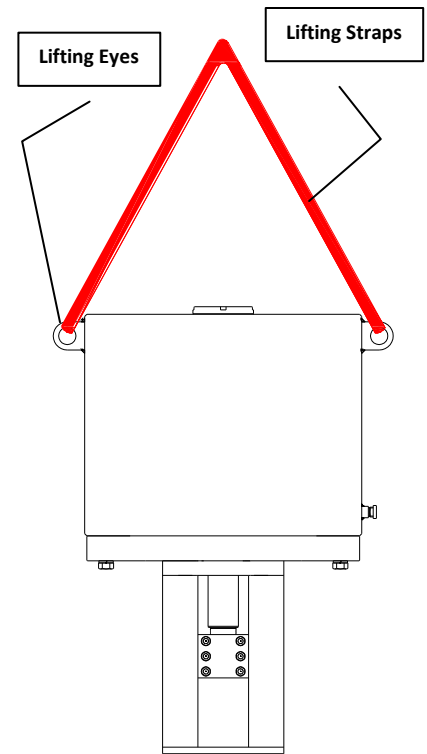

2. Revision Record

Rev. #	Issue Date	Description	Engr. Approval eSign & Date	Prepared by eSign & Date
I.R.	01/07/11	Initial Release	S. Michalcik, 1/27/11	Aneil Ali, 01/07/11
A	2/27/12	Updated Terms and Conditions	S. Michalcik, 2/27/12	Aneil Ali, 02/06/12

3. WARNING STATEMENT

BEFORE ATTEMPTING TO INSTALL, OPERATE, SERVICE, OR PERFORM MAINTENANCE ON ANY ATI ACTUATOR, ALL PERSONNEL INVOLVED SHOULD READ AND THOROUGHLY UNDERSTAND THIS MANUAL. THIS MANUAL DOES NOT CLAIM TO ADDRESS ALL SAFETY FACTORS ASSOCIATED WITH ATI ACTUATORS. IT IS THE RESPONSIBILITY OF THE USER TO ENSURE PROPER SAFETY, ALWAYS TAKE NECESSARY PRECAUTIONS AND UTILIZE PROPER PERSONAL PROTECTIVE EQUIPMENT (PPE) WHEN DEALING WITH COMPRESSED AIR, COMPRESSED HYDRAULIC FLUID, PINCH POINTS, AND ELECTRICITY.

VALVE AND ACTUATOR MUST BE RIGGED AND LIFTED SEPARATELY, NEVER AT THE SAME TIME. BEFORE RIGGING, ENSURE THE CRANE/HOIST/RIGGING HARDWARE LIFTING CAPACITY CAN SAFELY ACCOMMODATE THE DESIRED LOAD.

ACTUATORS AND VALVES COME INTO CONTACT WITH CAUSTIC GASES AND FLUIDS IN MANY APPLICATIONS. AS A RESULT, ALL TOXIC OR FLAMMABLE FUMES MUST BE VENTED AND LIQUIDS MOVED TO A SAFE LOCATION. THIS WILL HELP PREVENT PERSONNEL INJURY. THE INSTANTANEOUS RELEASE OF PRESSURE AND VENTING CAN PRODUCE NOISES DUE TO THE DISCHARGE AT SONIC VELOCITY. IT IS THE USER'S RESPONSIBILITY TO UTILIZE APPROPRIATE PROTECTION AGAINST HEARING DAMAGE TO ANY AND ALL NEAR THE ACTUATOR.

SPRING IS UNDER COMPRESSION. DO NOT ATTEMPT TO ADJUST OR DISMANTLE ANY PART OF THE SPRING MECHANISM WITHOUT CONSULTING THE MANUFACTURER, DOING SO MAY RESULT IN SEVERE INJURY OR EVEN DEATH. WHEN OPERATING DEVICE, ENSURE THAT ALL BODY PARTS, TOOLS, AND FOREIGN OBJECTS ARE CLEAR OF THE ACTUATOR'S ADAPTION BRACKET.

WARNING LABELS AND TAGS LOCATED ON THE ACTUATOR ARE MADE OF METAL FOILS THAT VARY IN THICKNESS. BECAUSE THE METAL TAGS HAVE SHARP EDGES, PERSONNEL INSTALLING, HANDLING, OR WORKING AROUND THE TAGS SHOULD PROTECT AGAINST CUTS OR INJURY.

PROPER INSTALLATION OF THE ACTUATOR IS CRITICAL TO PERFORMANCE AND SAFETY. DUE TO THE MANY VARIATIONS OF LINEAR ACTUATORS AND VALVES, THE FOLLOWING ARE GENERAL INSTRUCTIONS. THE TECHNICIAN FOLLOWING THESE INSTRUCTIONS MUST BE COMPETENT, TRAINED, AND HAVE A WORKING KNOWLEDGE OF VALVE ACTUATORS AND VALVES.

FOLLOWING THE ABOVE INSTRUCTIONS WILL HELP IN PREVENTING PERSONAL INJURY, PROPERTY DAMAGE, AND DAMAGE TO THE ACTUATOR.

4. Storage and Preservation Instructions

- 4.1. **CAUTION:** Actuators should not be stored in environments harmful to resilient seals. Never use any form of abrasive when cleaning rod surfaces.
- 4.2. Position actuator as it will be stored.
- 4.3. When actuators are stored, piston rods are often exposed to the outside elements for extended periods without cycling. Identify all exposed piston rod areas and pressure ports.
- 4.4. Pressure ports are plugged with plastic plugs during manufacturing/assembly. These plastic plugs should be removed and replaced with steel plugs; a sealant such as pipe dope or Teflon tape should be applied to steel plug threads.
- 4.5. Using a soft cloth dampened with an appropriate oil-based solvent: remove all dirt, dust, grease and contaminants from the exposed piston rod surface.
- 4.6. Inspect the piston rod for surface defects.
- 4.7. Apply a coating of rust preventative solvent to all exposed piston rod surfaces.
- 4.8. Periodically inspect the piston rod surfaces and apply additional rust preventative solvent as needed.
- 4.9. If the actuator will be moved and stored again, repeat the above steps.

For applications where the actuator is not put into immediate service it is recommended that the actuator be stored and preserved properly. Care should be taken to plug all open ports on actuator and controls to keep foreign particles and moisture from entering the actuator. Ideal actuator storage would allow for an indoor environment with a vertical storage position. For extended storage, please contact the manufacturer.

5. Installation

5.1. HORIZONTAL INSTALLATION

Special care must be taken when installing an actuator to a horizontal service orientation. To avoid cantilever loads on the valve stem and adaption bracket, it is the customer's duty to ensure proper support for the horizontal actuator. Proper support can range anywhere from ground supports to ceiling suspension.

5.2. SPLIT COUPLING

INSTALLATION PROCEDURE: (FULL CLOSE POSITION)

1. Position the subject valve to the full close position (tight shut off).
2. Remove the hand-wheel and hand-wheel drive assembly. (See Valve Assembly/Disassembly Instructions).
3. Position the Actuator in the full close (fully extended) position. This applies to the DA and SRR models only.
4. Remove the Cap Screws that fix the Actuator to the Adaptation Bracket and install two (2) ¼" shims, 180 degrees apart between the Actuator Lower Head and the Adaptation Bracket and reinstall the Cap Screws.
5. Remove the Coupling Block (ITEM 1) by removing (ITEM 2) cap screws.
6. Install the Adaptation Bracket onto the valve. The hardware may vary depending on the application and type of valve being actuated.
7. Install the Coupling Block (ITEM 1) on to the valve stem and Actuator piston rod (split coupling block) using cap screws (ITEM 2).
8. Install and tighten the (ITEMS 3,4,) fasteners. Fastener types and mounting positions may vary depending on your application.
9. Loosen Cap Screws connecting the Actuator Lower Head and Bracket, remove the two (2) shims previously installed and tighten Cap Screws.
10. Cycle Actuator fully opened and fully closed and ensure full stroke and smooth operation.

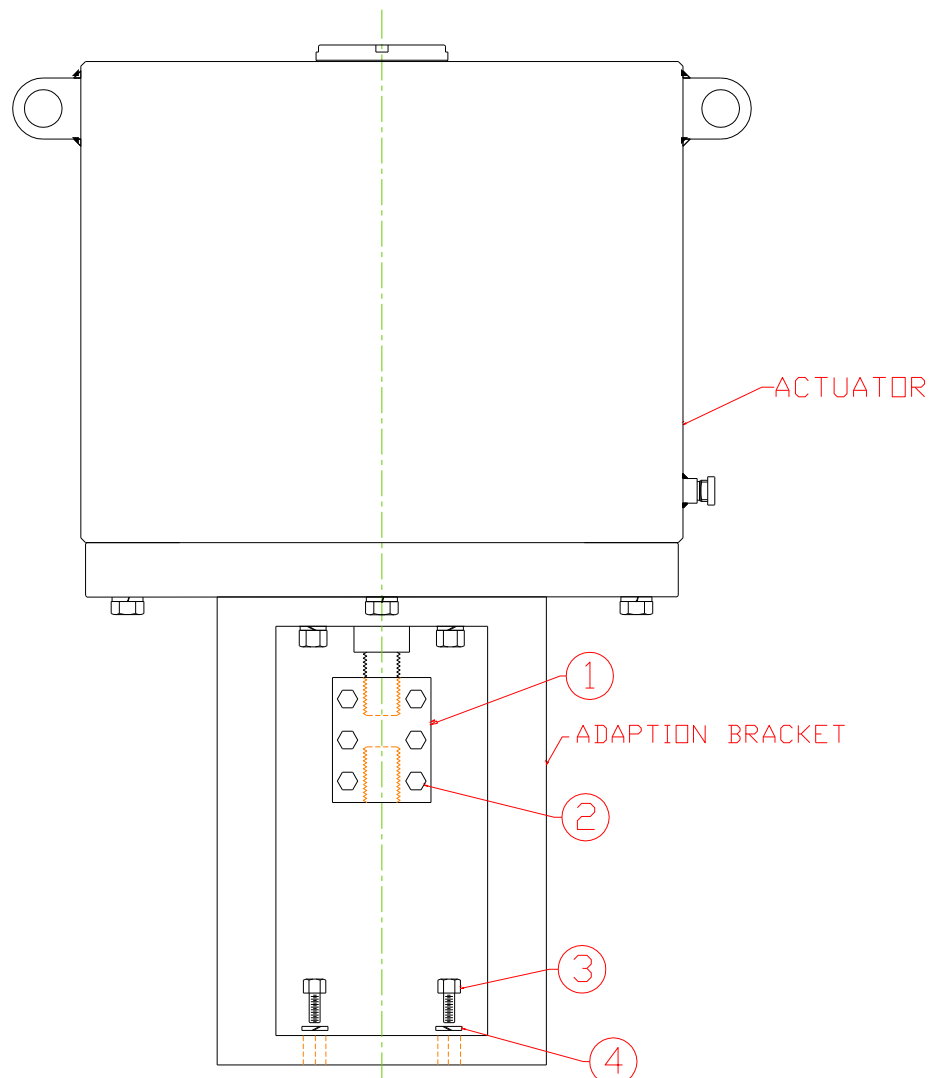

5.3. ADJUSTABLE STOPS, SPLIT BLOCK, Ref. Dwg: #8168

INSTALLATION PROCEDURE (FULL CLOSED POSITION)

1. Position the subject valve to the full closed position (TIGHT SHUT OFF).
2. Remove the valve hand wheel and hand wheel drive assembly. (SEE VALVE MANUFACTURERS ASSEMBLY/DISASSEMBLY INSTRUCTIONS).
3. Position the actuator in the full closed position (Piston rod (Item 1) fully extended).
4. If applicable, remove the final adaptation assembly (This assembly configuration varies per application) from the bottom of the basic adaptation bracket (Item 2).
5. If applicable, install final adaptation on subject valve.
6. Remove the position indicator guide, screws and lock washers, if Items exist on basic adaptation.
7. Remove the position indicator from the split coupling block (Item 3).
8. Remove split coupling block (Item 3) by removing bolts (Item 4) and lock washers (Item 5).
9. Position the actuator and the basic adaptation to the final adaptation or the valve as per application. Attach with the appropriate fasteners (Items 6 & 7) the recommended torque specs.
10. Install split coupling block (Item 3), by clamping on valve stem and piston rod (Item 1) threads. Coupling block groove must be clamped over split block guide (Item 8).
11. Reinstall bolts (Item 4) and lock washers (Item 5). Tighten to the recommended torque specs.
12. Reinstall position indicator to split coupling block (Item 3).
13. If applicable reinstall position indicator guide, screws and lock washers.
14. Cycle the actuator to check for full open and full close. Adjustments may be necessary.
15. Adjustments may be made by repositioning the stop adjustment bolts (Item 9) in split coupling block (Item 3). Loosen jam nut (Item 10), then reposition the stop adjusting bolts (Item 9), then cycle actuator for full open and full close.
16. Retighten jam nut (Item 10) to split coupling block (Item 3).

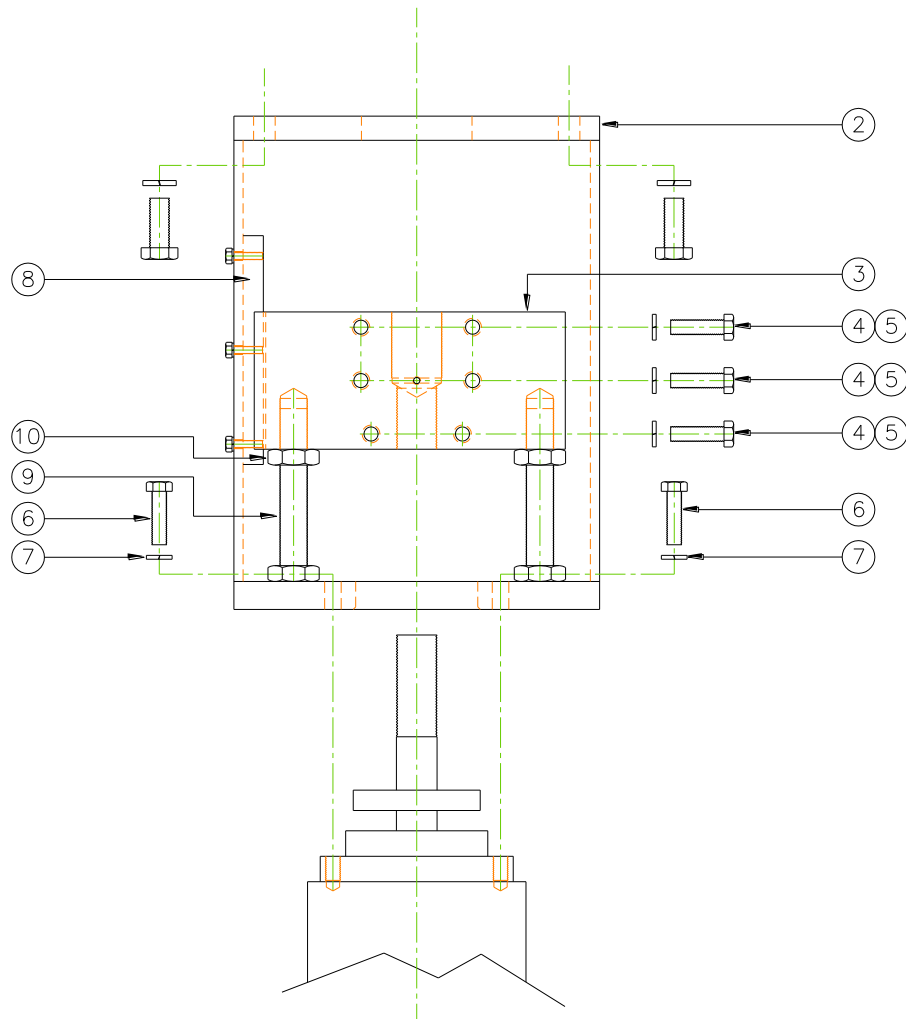

5.4. NO STOPS (SPLIT COUPLING), WITH ANTI-ROTATION PLATE, Ref. Dwg. #16720

INSTALLATION PROCEDURE: (FULL OPEN POSITION)

1. Position the subject valve to the full open position (tight shut off).
2. Remove the hand wheel and hand wheel drive assembly. (See Valve Assembly/Disassembly Instructions).
3. Position the actuator in the full retracted position. The SRR model will be in the retracted position without hydraulic pressure being applied.
4. Remove the coupling block (Item 1) by removing (Item 2) cap screws and lock washers (Item 3).
5. Install the actuator onto the valve. The hardware may vary depending on the application and type of valve being actuated.
6. Install the coupling block (Item 1) on to the valve stem and actuator piston rod. Make sure you have a minimum of one thread diameter of valve stem engaged into coupling block. Install anti-rotation plate (Item 4) thru slot in adaptation bracket and fasten it to coupling block (Item 1) using cap screws (Item 2) and lock washers (Item 3).
7. Cycle actuator fully opened and fully closed. Check for full stroke and smooth operation.

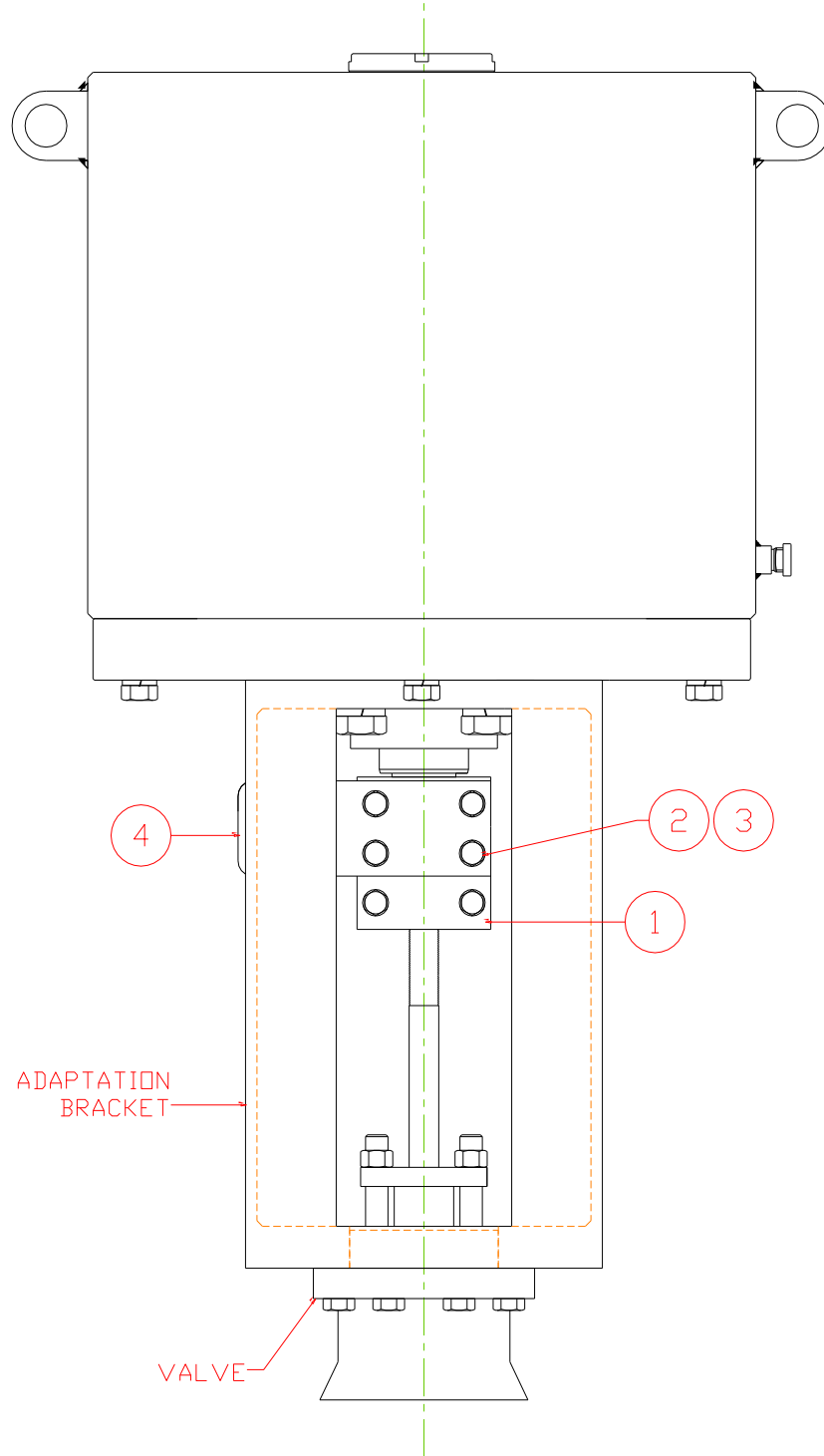

5.5. UP STOPS ONLY (SPLIT COUPLING BLOCK), Ref. Dwg. #6828

INSTALLATION PROCEDURE: (FULL CLOSE POSITION)

1. Position the subject valve to the full close position (tight shut off).
2. Remove the hand wheel and hand wheel drive assembly. (See Valve Assembly/Disassembly Instructions).
3. Position the Actuator in the full close (fully extended) position.
4. Remove the split coupling block (Item 1) by removing (Item 2) cap screws and lock washers (Item 6).
5. Install the actuator onto the valve, leaving a 1/8" gap between the adaptation bracket and valve. The hardware may vary depending on the application and type of valve being actuated.
6. Install the split coupling block (Item 1) on to the valve stem and actuator piston rod, using cap screws (Item 2) and lock washers (Item 6). Make sure you have at least one full thread diameter of valve stem engaged into split coupling block. Coupling block should be clamping on split block guide (Item 3).
7. Install and tighten the fasteners required for holding the valve to the actuator. Fastener types and mounting positions may vary depending on your application. Tighten fasteners to torque specifications on torque chart provided.
8. Cycle Actuator fully opened and fully closed and ensure full stroke and smooth operation.
9. Adjust stop bolts (Item 4) for valve stroke and tighten jam nuts (Item 5) down on coupling block (Item 1) to torque specifications on torque chart.

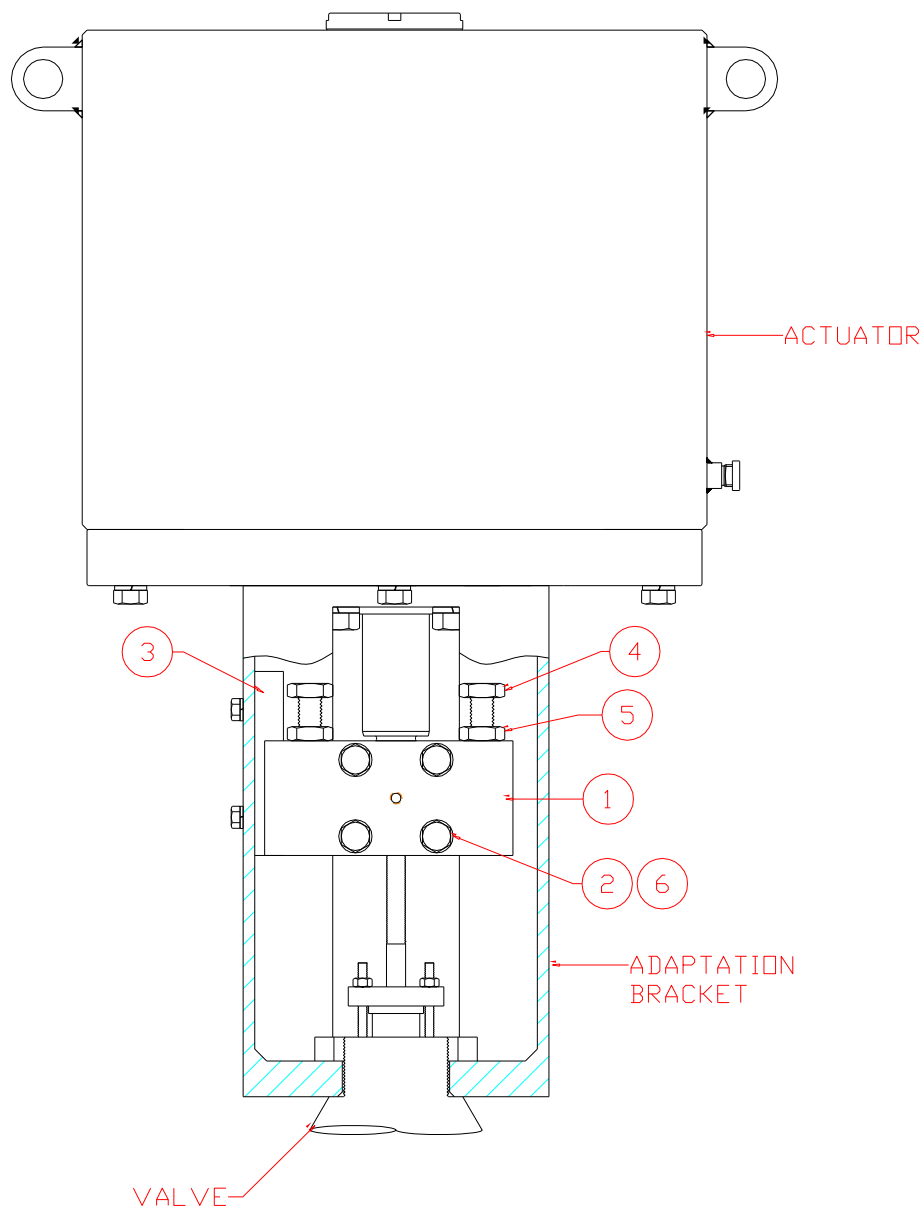

5.7. "HDH" SERIES LINEAR ACTUATORS, ADJUSTABLE STOPS, Ref. Dwg. #6045

INSTALLATION PROCEDURE: (FULL CLOSED POSITION)

1. Position the subject valve to the full closed position (tight shut off).
2. Remove the valve hand wheel and hand wheel drive assembly. (See valve manufacturer's assembly/disassembly instructions).
3. Position the actuator in the full closed (piston rod (Item 1) fully extended) position.
4. Remove the coupling block assembly (Item 2) by removing the coupling block bushing retaining cap screw and lock washer (Items 3 & 4) from the coupling block.
5. Remove the pin spanner wrench (Item 5) from inside the adaption bracket.
6. Position spanner wrench (Item 5) in holes located in the coupling block bushing (Item 6) and turn counter clockwise until completely out of the coupling block. It is not necessary to remove the piston rod insert (Item 7) or set screw (Item 8).
7. Position the actuator in the full open position.
8. Remove position indicator guide (Item 9) screws (Item 10) and lock washers (Item 11).
9. Remove position indicator (Item 12) and stud (Item 13).
10. Position actuator and adaption bracket to final adaption or valve as per application. Attach with appropriate fasteners to recommended torque specs.
11. Position coupling block assembly over valve stem and thread on clockwise for right hand threads or counter clockwise for left hand threads. Thread down on valve stem until bottom of coupling block assembly is within 1/8" to 1/4" of the bottom of the adaption bracket. It is not necessary to remove threaded insert (Item 15).
12. Align the coupling block assembly to locate the position indicator hole with centerline of the adaption bracket.
13. Position the actuator in the full closed position (piston rod (Item 1) fully extended) position very slowly to install piston rod into the coupling block assembly.
14. Reinstall coupling block bushing (Item 6) with pin spanner wrench (Item 5). NOTE: DO NOT FULLY TIGHTEN UNTIL STEP 16 IS COMPLETED.
15. Reinstall position indicator (Item 12) and stud (Item 13).
16. Reinstall position indicator guide (Item 9) screws (Item 10) and lock washers (Item 11).
17. Tighten coupling block bushing (Item 6) with pin spanner wrench (Item 5), then install coupling block bushing retaining cap screw and lock washer (Items 3 & 4).
18. Cycle actuator and check for full open and full close. Adjustment may be necessary.
19. Adjustment may be made by repositioning the stop adjustment bolts (Item 14).
20. Reinstall pin spanner wrench on inside adaptation bracket.

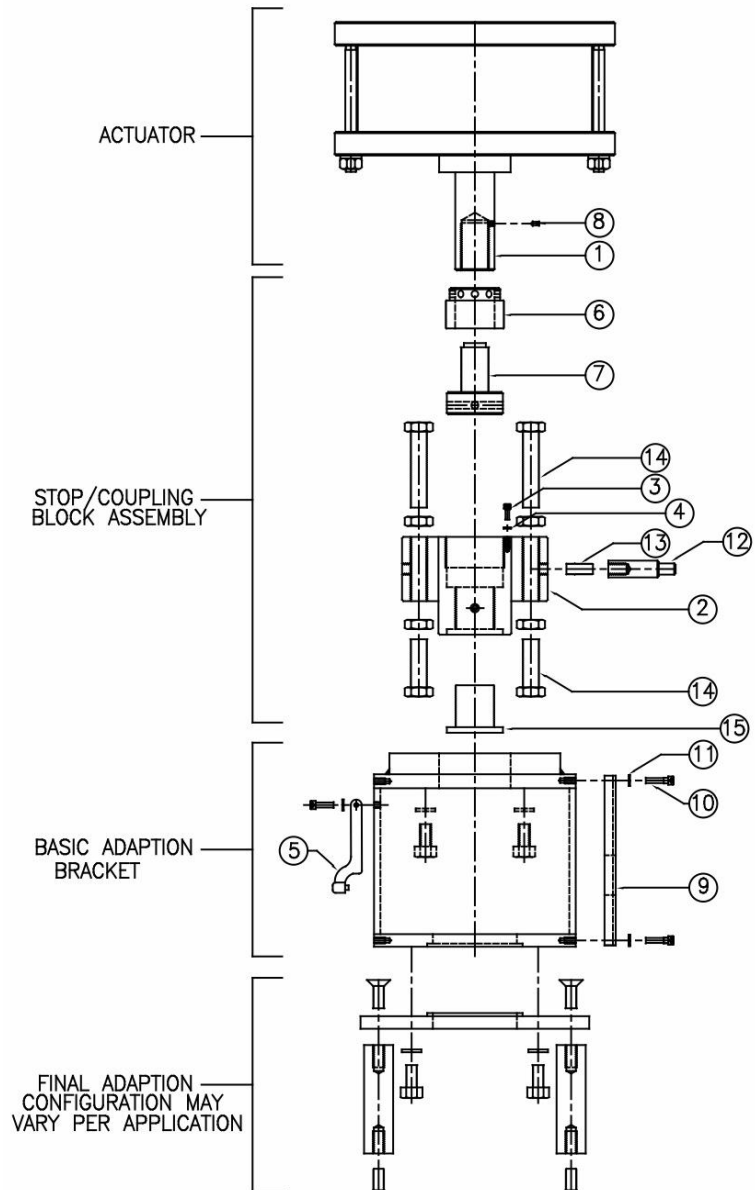

6. Testing

- 6.1. Following the installation, standard testing procedures must be followed to ensure proper actuator function.
- 6.2. Connect all necessary hose fittings to the corresponding labeled ports.
- 6.3. Pressurize the lower side of the piston cavity. Ensure that the open/close time and reaction time satisfy specification.
- 6.4. Ensure that the piston rod retracts upon loss of hydraulic pressure or electricity.

7. Maintenance

- 7.1. As a result of their robust design and corrosion resistant coatings, ATI Actuators require a minimum amount of maintenance. As with any mechanical application, the service interval is determined by the conditions of use. In an ideal environment the customary service interval is five years. More frequent service may be required in harsh environments.

The Standard contents in the Manufacturer's Maintenance Seal Kit are listed below. If additional seals are required for your actuator, they will be provided with the Manufacturer's Maintenance Seal Kit.

Manufacturer's Maintenance Seal Kit		
ITEM	QTY.	PART DESCRIPTION
A	2	HEAD SEAL O-RINGS, F/HEAD
	2	PARBAKS
B	1	PISTON T-SEAL, 2 BACK UP RINGS
C	2	PISTON WEAR BANDS
D	1	PISTON ROD O-RING
	2	PARBAKS
E	2	BEARING O-RINGS
	2	PARBAKS
F	2	BEARING ROD T-SEAL, 2 BACK UP RINGS
G	2	ROD WIPER RINGS
H	1	O-RING FOR ACCESS CAP

7.2. Seal Replacement Instructions (Reference Drawing # 13884)

1. Please see the graphic provided below to assist with disassembly and seal replacement.
2. Before rigging, ensure the crane/hoist/rigging hardware lifting capacity can safely accommodate the desired load.
3. Attach rigging hardware and straps to lifting eyes on spring cartridge.
4. With the valve already detached, place actuator in the upright position on a disassembly platform.
5. Loosen/remove the access cap (Item 2).
6. Loosen/remove the hex head cap screw and lock washer (Items 3 and 4).
7. Remove Seal H from the access cap (Item 2).
8. Using proper lifting hardware and equipment, flip actuator so that the lower head (Item 19) is facing up.
9. Loosen/remove socket head cap screws, bearing retaining ring, and bearing (Items 12, 11, and 10).
10. Loosen/remove hex head cap screws and lock washers (Items 20 and 21) from lower head (Item 19).
11. Thread lifting eyes into lower head (Item 19).
12. Attach lifting straps and lift actuator assembly from spring cartridge (Item 1).
13. Using proper lifting hardware and equipment, flip actuator so that the upper head (Item 6) facing up. Place on a flat surface.
14. Loosen male elbow and male connector (Items 17 and 18) on the hydraulic tubing.
15. On the upper head (Item 6): Loosen/remove socket head cap screws, bearing retaining ring, and bearing (Items 12, 11, and 10).
16. In a criss-cross pattern, loosen/remove hex head nuts and lock washers (Items 13 and 14) from upper head (Item 6).
17. Thread lifting eyes in upper head (Item 6).
18. Attach lifting straps and remove upper head (Item 6) from cylinder (Item 7).
19. Thread lifting eye into the hydraulic piston rod (Item 5).
20. Lift piston, hydraulic piston rod, and lower piston rod assembly (Items 9, 5, 15) out of the cylinder (Item 7).
21. Remove tie rods (Item 8) from the lower head (Item 19).
22. Remove piston T-seal and wear bands (Items B and C) from piston (Item 9).
23. Thread locking compound is applied to the piston rod threads by the manufacturer during initial assembly. As a result, disassembly will require heating to loosen the thread locking compound. To remove the piston rod seal (Item D), heat the piston assembly using a torch and unthread piston rod from piston (Item 6).
24. Be careful not to handle the piston rod until it has completely cooled.
25. To ensure all seals are removed/replaced, refer to *Detail 1* and *Detail 2* in the diagram on the following page.
26. Refer to ATI MP1012 Hydraulic SRR Assembly Procedure for reassembly after seal replacement.

BILL OF MATERIALS		
ITEM NO.	QTY.	DESCRIPTION
1	1	SPRING CARTRIDGE ASSEMBLY
2	1	ACCESS CAP
3	1	HHCS, 1 1/2-12UNC X 3.250
4	1	LOCK WASHER, 1 1/2"
5	1	HYD. PISTON ROD
6	1	SR HEAD
7	1	CYLINDER
8	*	TIE BOLT
9	1	PISTON
10	2	BEARING
11	2	BEARING RETAINING RING
12	*	SHCS, 5/16-18UN X 1" LG.
13	*	HHN, 3/4-16UNF
14	*	LOCK WASHER, 3/4"
15	1	LOWER PISTON ROD
16	1	BREATHER VENT
17	1	MALE ELBOW, 3/8T×3/8MNPT
18	1	MALE CONNECTOR, 3/8T×3/8MNPT
19	1	SRR LOWER HEAD
20	*	HHCS, 3/4-10UNC X 3.250
21	*	LOCK WASHER, 3/4"
22	1	SEAL KIT
23	1	MALE ELBOW, 1/2" NPT
24	1	CHECK VALVE, 1/2" NPT

* Quantity Varies

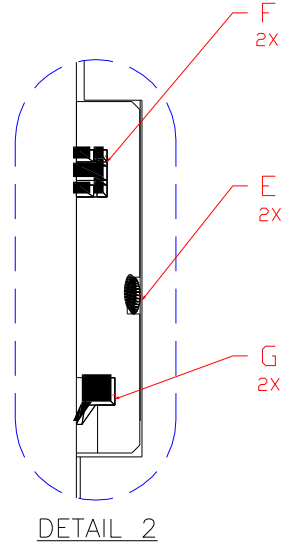
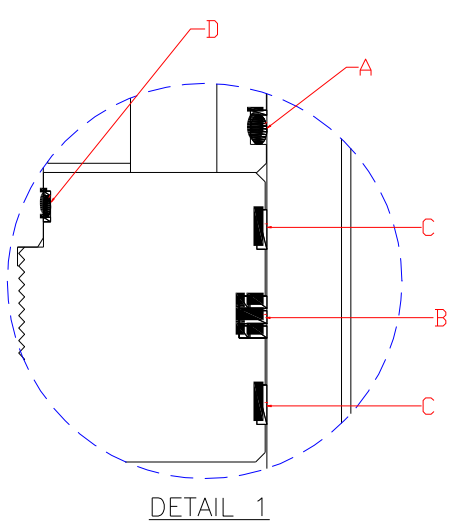
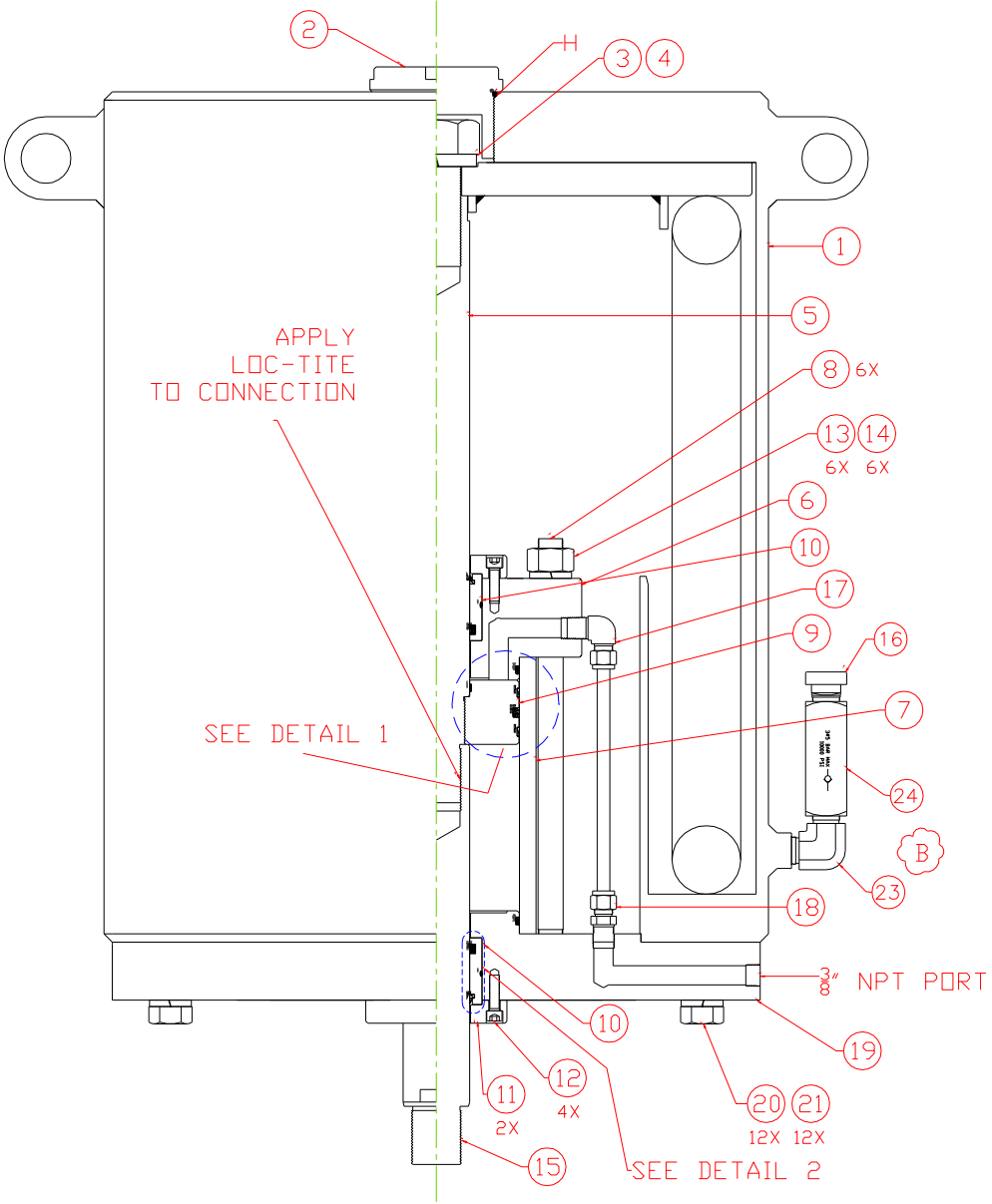

8. Terms & Conditions/Warranty

Except as otherwise expressly agreed to in writing by an authorized representative of Automation Technology, Inc. (hereinafter "ATI"), the following terms and conditions (these "Terms and Conditions") shall apply to all offers for the purchase or sale of products manufactured or supplied by ATI under brand names including, but not limited to "ATI", "Gevalco", etc.

A. **CONDITIONAL ACCEPTANCE; REJECTION OF PURCHASER TERMS** – All orders and acknowledgements of Purchaser shall constitute only consent to these Terms and Conditions and a representation that Purchaser is solvent. All quotations and offers of sale by ATI are expressly limited to these Terms and Conditions and are subject to written acceptance by ATI. Any such acceptance by ATI is expressly conditioned upon assent of Purchaser to these Terms and Conditions, and ATI hereby expressly objects to and rejects as material alterations to these Terms and Conditions any terms or conditions of Purchaser, whether contained in Purchaser's order, acknowledgement or otherwise, that are different from or in addition to these Terms and Conditions.

B. **PRICES** - ATI quotations are valid for thirty (30) days from date of issuance, unless otherwise stated by ATI in writing, and are subject to withdrawal or change at any time prior to acceptance by ATI. Prices are ex works, in United States Dollars, and firm for thirty (30) days from date of ATI's written acceptance of Purchaser's order and an unconditional authorization for the immediate manufacture based on customer supplied information. If for any reason authorization does not commence within such thirty (30) days, prices in effect at the time of release for manufacture will apply, unless otherwise stated in writing. All sales, use, excise, value-added, import, export and other taxes, duties, customs and the like (collectively "Taxes") are the responsibility of Purchaser and will be added to the price to the extent that ATI pays on Purchaser's behalf or is required by law to pay in connection with the sale. ATI reserves the right to invoice and be paid for any Tax at the time of shipment or any time thereafter. All orders are subject to laws and regulations that are in effect and that become effective prior to delivery. Typographical or clerical errors in quotations, orders and acknowledgements are subject to correction by ATI. Prices do not include installation or any other service, unless so stated expressly in the quotation or ATI's order acknowledgement. Prices include one (1) copy of any applicable manuals. Any additional manuals or other printed materials requested by Purchaser are subject to additional cost, to be quoted at or near the time that such materials are requested by Purchaser.

C. **PAYMENT** - Payment from Purchaser is due within thirty (30) days from date of first invoice, unless otherwise stated on ATI's quotation or order acknowledgement. For international orders, ATI reserves the right to require, before commencing filling the order, security in the form of a letter of credit or the like, in a form and from a bank or guarantor acceptable to ATI. Subject to any applicable usury law that would void or render invalid or unenforceable this sentence, in which case the specified rate will be deemed to be reduced to the maximum allowed by law, simple interest at the rate of 1.5 percent per month will apply to balances unpaid within 30 days from date of first invoice. ATI will invoice upon making available for shipment. ATI reserves the right to payment and Purchaser will be responsible for any cost associated with storage of products or delay in making products available for pickup that occurs at the request of Purchaser.

D. **FORCE MAJEURE** – In no event shall ATI be liable for non-delivery or delay in delivery, or for failure or delay in the performance of any obligation contained herein, that arises directly or indirectly from acts of God, unforeseeable circumstances, acts (including delays or failure to act) of any governmental authority (de jure or de facto), war (declared or undeclared), terrorism, riot, revolution, priorities, fires, floods, weather, strikes, labor disputes, sabotage, epidemics, factory shutdowns or alterations, embargoes, delays or shortages in transportation, delay in obtaining or procuring or inability to obtain or procure labor, materials or manufacturing facilities, delay in obtaining or inability to obtain timely instructions or information from the Purchaser, or any other cause or circumstance of any other kind beyond ATI's reasonable control. The foregoing provision shall apply even though such causes or circumstances may occur after ATI's performance has been delayed for other causes or circumstances.

E. **SHIPPING** – (a) Products are sold ex works. Risk of loss is the responsibility of and title transfers to Purchaser once products are made available at Seller's facility for pickup by Purchaser or its carrier.

(b) Acknowledged ship dates represent the estimated date of availability for pickup, rather than actual shipment or delivery at destination for which Purchaser is responsible. All indicated shipping dates are estimates, based on prompt receipt of all necessary information from Buyer necessary to process the order. ATI will use its best reasonable efforts to make products available for pickup by such dates, but there is no guarantee to do so. Indicated time periods for pickup availability are estimated from the latest to occur of: 1) ATI's acceptance of Purchaser's order, 2) ATI's receipt of valve dimensional information, if applicable, 3) ATI's receipt of Purchaser supplied components required to manufacture or supply the products, if applicable, or 4) ATI's receipt of drawings approved by Purchaser. Products ordered on an "in stock" basis are subject to prior sale to other customers. Acknowledged ship dates are subject to changes caused by additions to or modification of the original order agreed to by both Purchaser and ATI.

(c) Under no circumstances shall ATI have any liability whatsoever for loss of use or for any indirect or consequential damages as a result of delayed delivery.

(d) Purchaser is responsible for payment of carrier and all other shipping costs and for making all arrangements necessary for pickup, transport, export, import and delivery to Purchaser's destination. Without prejudice to any ex works rights of ATI and obligations of Purchaser, Purchaser consents in advance to ATI shipping collect any products that Purchaser fails to pick up, and Purchaser will remain responsible for all associated pickup, transport, export, import and delivery costs, including any unknown to ATI or Purchaser at the time of shipment.

F. **DESIGN** - Due to continuous product development, ATI reserves the right to modify designs, materials and specifications without prior notice.

G. CANCELLATION - Orders acknowledged by ATI are not subject to cancellation or suspension except with the advance written consent of ATI and upon terms which will compensate ATI for and indemnify ATI from and against loss or damage occasioned by such cancellation or suspension, including without limitation for all costs and expenses already incurred or commitments made by ATI in connection with the processing, purchasing, handling, and fabrication of equipment for the order and a reasonable profit thereon. ATI's determination of such termination charges shall be conclusive.

H. INSPECTION - Final inspection and acceptance of products must be made at ATI's facility and shall constitute a waiver by Purchaser of any claim for loss or damage, except for latent defects not reasonably discoverable by such inspection. Purchaser's representative may inspect products during normal business hours and must do so in a manner that does not interfere with ATI operations.

I. ATI WARRANTY; EXCLUSIVE PURCHASER REMEDY – All products manufactured by ATI are warranted against defects in material and workmanship for a period of two (2) years after the date that the products were made available for pickup by Purchaser. ATI's warranty excludes any defects resulting from improper or abnormal shipping, operation or maintenance. Purchaser must immediately, and in no event later than thirty (30) days after becoming aware of a suspected defect, notify ATI in writing of any such suspected defect. Within a reasonable time following ATI's receipt of such notice, investigation and confirmation of a defect, ATI will have the right and the obligation, in its sole discretion, to repair at no cost to Purchaser such defect or replace the defective product or component thereof with a non-defective product or component thereof. Repair or component replacement by non-ATI authorized agents WILL VOID all remaining warranty on the product. Products purchased by ATI from a third party for resale to Buyer ("Resale Products") shall carry only the warranty extended by the original manufacturer. ATI's repair or replacement obligations under this Paragraph I do not extend to any labor or other loss or damage occasioned by, incidental to, or in consequence of any such defect. Purchaser's sole and exclusive remedy and ATI's obligation and liability for breach of warranty are expressly limited to such repair or replacement. Goods repaired or replaced during the warranty period shall be in warranty for the remainder of the original warranty or ninety (90) days, whichever is longer. All other remedies of Purchaser are hereby expressly excluded. THE WARRANTY CONTAINED IN THIS PARAGRAPH I IS THE SOLE AND EXCLUSIVE WARRANTY PROVIDED BY ATI WITH RESPECT TO ITS PRODUCTS AND SUPERSEDES AND IS IN LIEU OF ANY AND ALL OTHER WARRANTIES, WHETHER EXPRESS, IMPLIED, STATUTORY OR OTHERWISE, INCLUDING WITHOUT LIMITATION ANY IMPLIED WARRANTY OF MERCHANTABILITY OR FITNESS FOR PARTICULAR PURPOSE, ALL OF WHICH ARE HEREBY EXPRESSLY DISCLAIMED. Purchaser acknowledges and agrees that ATI Manuals, printed materials and any other documentation do not constitute warranties of any kind, including with respect to quality or performance. Purchaser is expected to determine the suitability of ATI products for ordinary and Purchaser's particular purposes.

J. EXCLUSION OF CONSEQUENTIAL DAMAGES; LIMITATION OF DIRECT DAMAGES - ATI shall not be liable for and Purchaser shall have no right to recover from ATI for any indirect, special or consequential damages, even if ATI has actual notice of any special circumstances from which any such damages might arise. Moreover, subject to Paragraph I which would completely bar any such recovery of direct damages if ATI honors its warranty, in no event shall any recovery of direct damages against ATI exceed the amount of the order price attributable to the portion of the product or products that is determined to have caused any alleged loss, damage or injury that is compensable under these Terms and Conditions and not remedied by ATI.

K. RETURNS – No product may be returned for credit or adjustment without written permission and tagging instruction from ATI. Upon receipt of approved returns, any handling/restocking charges and/or cost to recondition for resale, will be the responsibility of Purchaser.

L. GOVERNING LAW; VENUE AND JURISDICTION - All sales of products by ATI and any disputes arising out of or related to such sales or products or these Terms and Conditions shall be governed by, and these Terms and Conditions shall be construed in accordance with, the laws of the State of Texas, without regard to its conflicts of law principles that would apply the law of another jurisdiction. The United Nations Convention on Contracts for the International Sale of Goods is expressly disclaimed by and excluded from these Terms and Conditions. ATI's offer of sale may only be accepted in Harris County, Texas and any resulting contract is performable in whole or in part in Harris County, Texas. Venue for any litigation arising out of such sale, products or contract shall be proper in the state or federal district courts of Houston, Harris County, Texas, U.S.A., to the exclusive jurisdictions of which Purchaser hereby expressly submits.

M. NON-WAIVER – Any waiver by ATI of any breach of any of these Terms and Conditions must be set forth in a writing signed by an authorized representative of ATI and shall not constitute a waiver of or otherwise prejudice ATI's right to demand strict performance of any other term or condition of these Terms and Conditions.

N. REMEDIES CUMULATIVE – ATI's remedies pursuant to these Terms and Conditions and applicable law are cumulative in nature and election or pursuit of any such remedy shall not prohibit ATI from electing or pursuing any other such remedy.

O. SEVERABILITY – In the event that any provision or portion of any provision of these Terms and Conditions is held void, invalid or unenforceable, such void, invalid or unenforceable provision or portion thereof shall be deemed severed from these Terms and Conditions, and the balance of these Terms and Conditions shall remain in full force and effect.

P. EXPORT / IMPORT - Buyer agrees that all applicable import and export control laws, regulations, orders, and requirements, including without limitations those of the United States will apply to the receipt and use of the Goods and Services provided by ATI. In no event shall Buyer use, transfer, release, import, export, re-export Goods in violation of such applicable laws, regulations, orders, or requirements.

Q. BUYER SUPPLIED DATA – To the extent that Seller has relied upon any specification, information, representation of operating conditions or other data or information supplied by Buyer to ATI, in the selection, or design of the Goods and the preparation of ATI's quotation, and in the event that actual operating conditions or other data differ from those represented by Buyer and relied on by ATI, any warranties or other provisions contained herein are null and void. To the degree such data errors cause re-design or re-manufacture of the Goods, Buyer shall be responsible for additional costs incurred by ATI.

Appendix

Appendix A – MP1008 ATI Torque Tightening Guide

STAT-O SEALS OR THREAD SEALS							
COARSE THREADS				FINE THREADS			
BOLT DIA.	CLAMP LOAD LBS.	PLAIN (FT-LBS)	PLATED (FT-LBS)	BOLT DIA.	CLAMP LOAD LBS.	PLAIN (FT-LBS)	PLATED (FT-LBS)
1/4-20	2,850	7	5	1/4-28	3,263	8	6
5/16-18	4,725	13	10	5/16-24	5,113	14	11
3/8-16	6,975	23	18	3/8-24	7,875	25	20
7/16-14	9,600	36	27	7/16-20	10,650	38	29
1/2-13	12,750	54	42	1/2-20	14,400	57	46
9/16-12	16,350	77	60	9/16-18	18,300	63	67
5/8-11	20,325	108	82	5/8-18	23,025	113	92
3/4-10	30,075	189	145	3/4-16	33,600	209	160
7/8-9	41,550	305	231	7/8-14	45,825	335	251
1-8	54,525	456	342	1-12	59,700	498	355
1-1/8-7	68,700	647	487	1-14	61,125	510	383
1-1/4-7	87,225	912	683	1-1/8-12	77,025	724	542
1-3/8-6	103,950	1197	896	1-1/4-12	96,600	1008	755
1-1/2-6	126,450	1585	1187	1-3/8-12	118,350	1357	1025
				1-1/2-12	142,275	1779	1335

ATI TIGHTENING TORQUE GUIDE FOR TIE RODS (100K STRESS PROOF)			
COARSE THREADS		FINE THREADS	
BOLT DIA.	TORQUE FT-LBS AT 100,000 PSI	BOLT DIA.	TORQUE FT-LBS AT 100,000 PSI
1/4-20	6	1/4-28	8
5/16-18	11	5/16-24	13
3/8-16	19	3/8-24	21
7/16-14	29	7/16-20	32
1/2-13	44	1/2-20	47
9/16-12	62	9/16-18	65
5/8-11	85	5/8-18	88
3/4-10	146	3/4-16	152
7/8-9	231	7/8-14	241
1-8	328	1-14	347
1-1/8-7	488	1-1/8-12	498
		1 1/4-12	600

ATI TIGHTENING TORQUE GUIDE(SAE GRADE 8 FASTENERS)							
COARSE THREADS				FINE THREADS			
BOLT DIA.	CLAMP LOAD LBS.	PLAIN (FT-LBS)	PLATED (FT-LBS)	BOLT DIA.	CLAMP LOAD LBS.	PLAIN (FT-LBS)	PLATED (FT-LBS)
1/4-20	2,850	12	9	1/4-28	3,263	14	10
5/16-18	4,725	25	18	5/16-24	5,113	27	20
3/8-16	6,975	44	33	3/8-24	7,875	49	37
7/16-14	9,600	70	52	7/16-20	10,650	78	58
1/2-13	12,750	106	80	1/2-20	14,400	120	90
9/16-12	16,350	153	115	9/16-18	18,300	172	129
5/8-11	20,325	212	159	5/8-18	23,025	240	180
3/4-10	30,075	376	282	3/4-16	33,600	420	315
7/8-9	41,550	606	454	7/8-20/14	45,825	668	501
1-8	54,525	909	682	1-12	59,700	995	746
1-1/8-7	68,700	1288	966	1-14	61,125	1019	764
1-1/4-7	87,225	1817	1363	1-1/8-12	77,025	1444	1083
1-3/8-6	103,950	2382	1787	1-1/4-12	96,600	2012	1509
1-1/2-6	126,450	3163	2371	1-3/8-12	118,350	2712	2034
				1-1/2-12	142,275	3557	2668